

## Piano Secondo

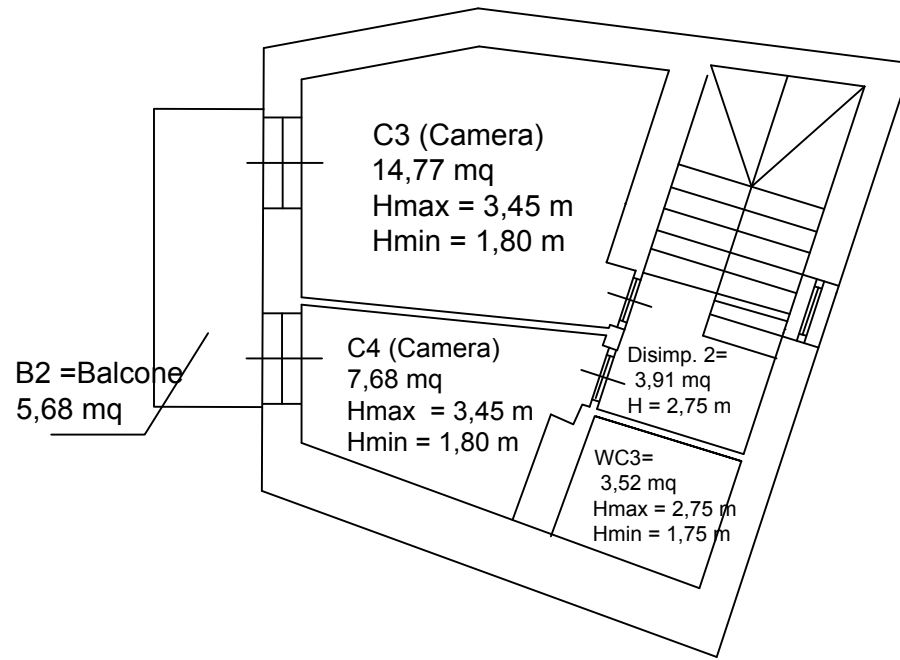

## Piano Primo

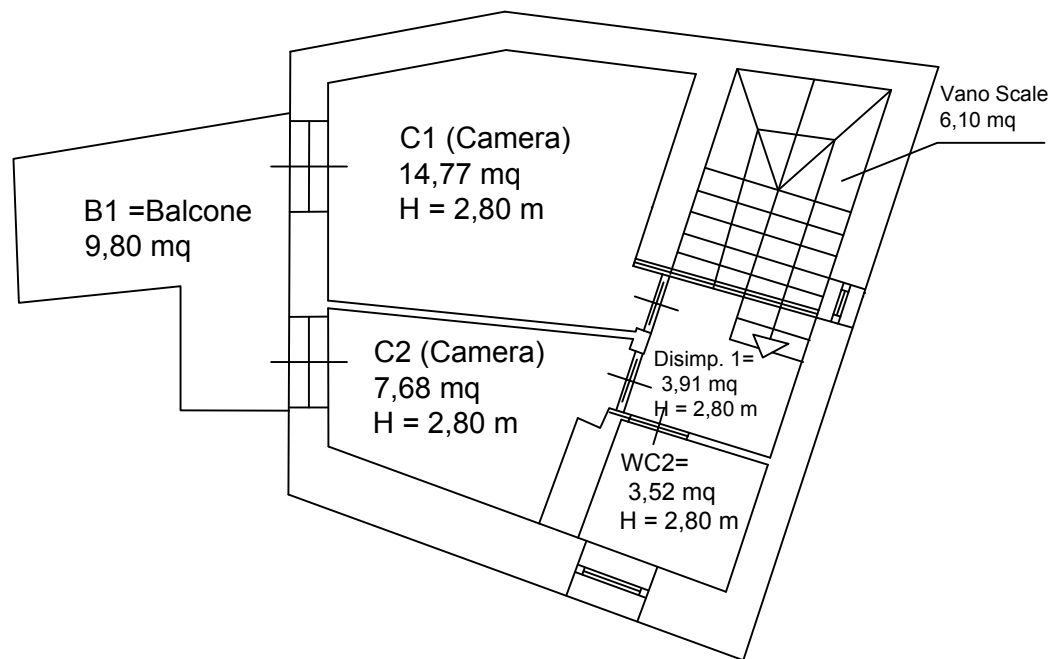

## Piano Terra

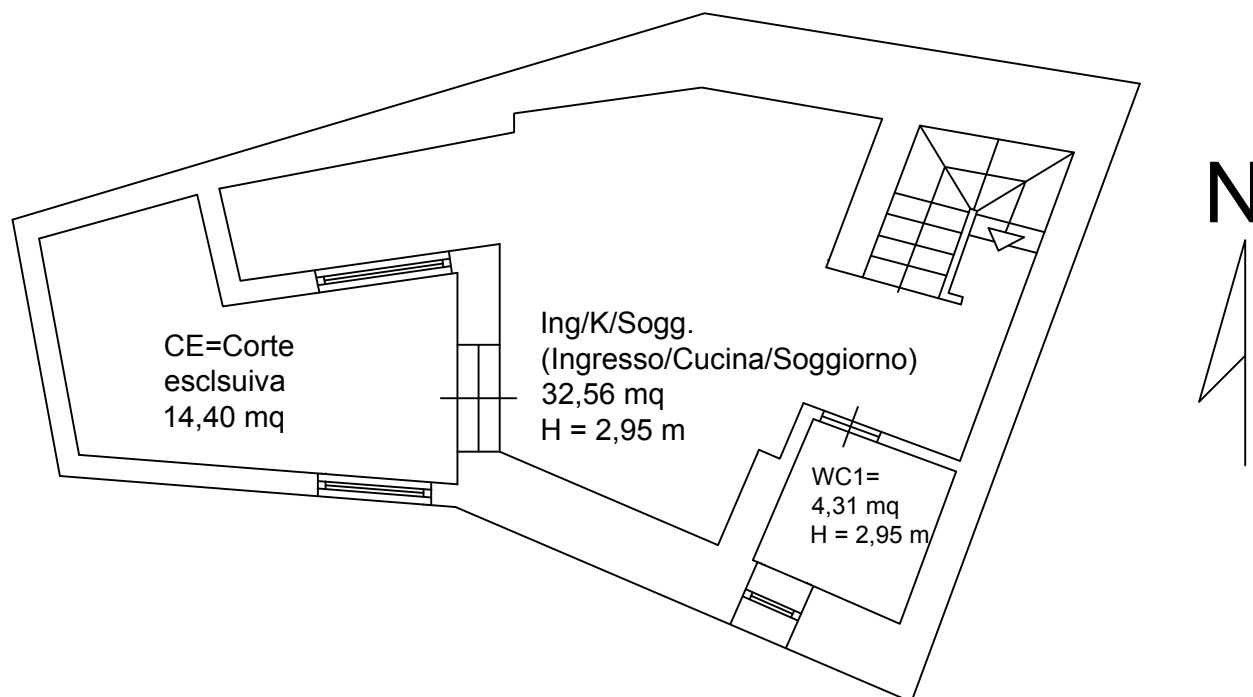

**R.G. n. 193/2019**

ing. Stefania Sellitti, via Barbarulo n°78 – Nocera Inferiore –  
tel/fax 081 929055 e-mail stefaniasellitti@libero.it  
pec: stefania.sellitti@ordingsa.it

**Allegato E: Rilievo planimetrico immobile staggito**

Tribunale di Nocera Inferiore (SA)