

FOTO DI CONTESTO



Figura 1 - Ortofoto circondario ed individuazione fabbricato ed uiv

FOTO ESTERNE



Figura 2/3 - Foto d'insieme scorcio e individuazione immobile su Via Alessandro Volta: 2) scorcio Sud->Nord 3) scorcio Nord->Sud



Figura 4 - Foto prospetto via Alessandro Volta: Ripresa intero Fabbricato

Unita' Immobiliare Garage - Fg 42- Plla 142 Sub 3

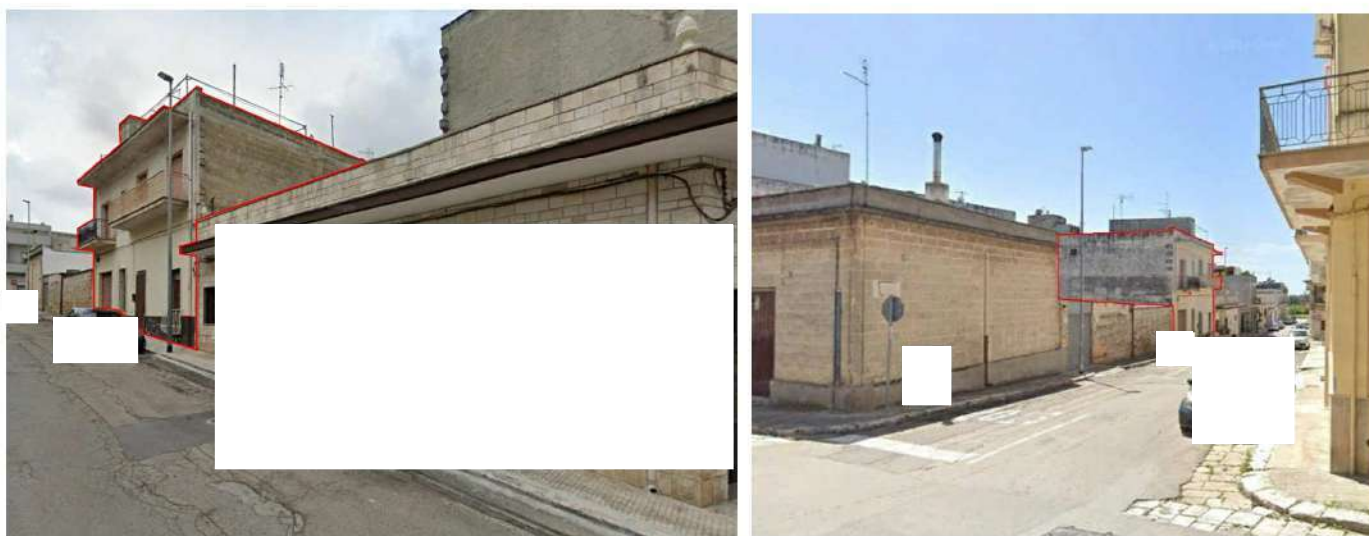

LOTTO 2

Figura 5 - Foto 1: prospetto via Alessandro Volta: individuazione Uiu Fg 42- Plla 142 Sub 3

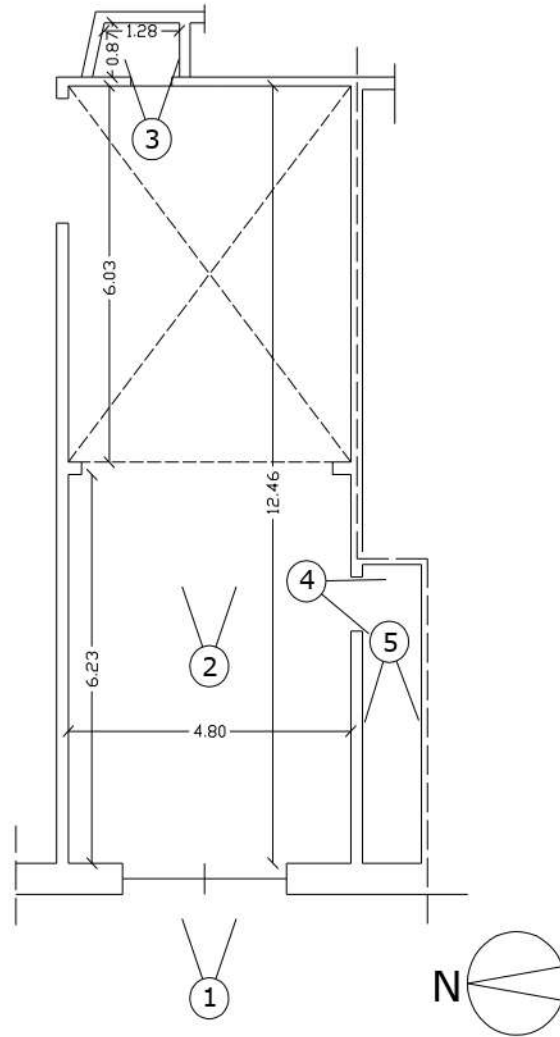

Foglio 42 P.IIa 142 Sub 3

Figura 10 – Planimetria Unità Immobiliare Garage

FOTO INTERNE



Figura 6 – Foto.2: vista insieme interno



Figura 7- Foto.3: Vano igienico Wc



Figura 8 – Foto.4: vista accesso ripostiglio



Figura 9- Foto.5: Vano ripostiglio