

ALLEGATO A

Planimetria dell'immobile e documentazione fotografica

STATO DI FATTO - Immobile in via Madonna dei Canneti 52 Cerveteri (RM)
PIANTA PIANO 2
Appartamento - interno 14
scala 1:100

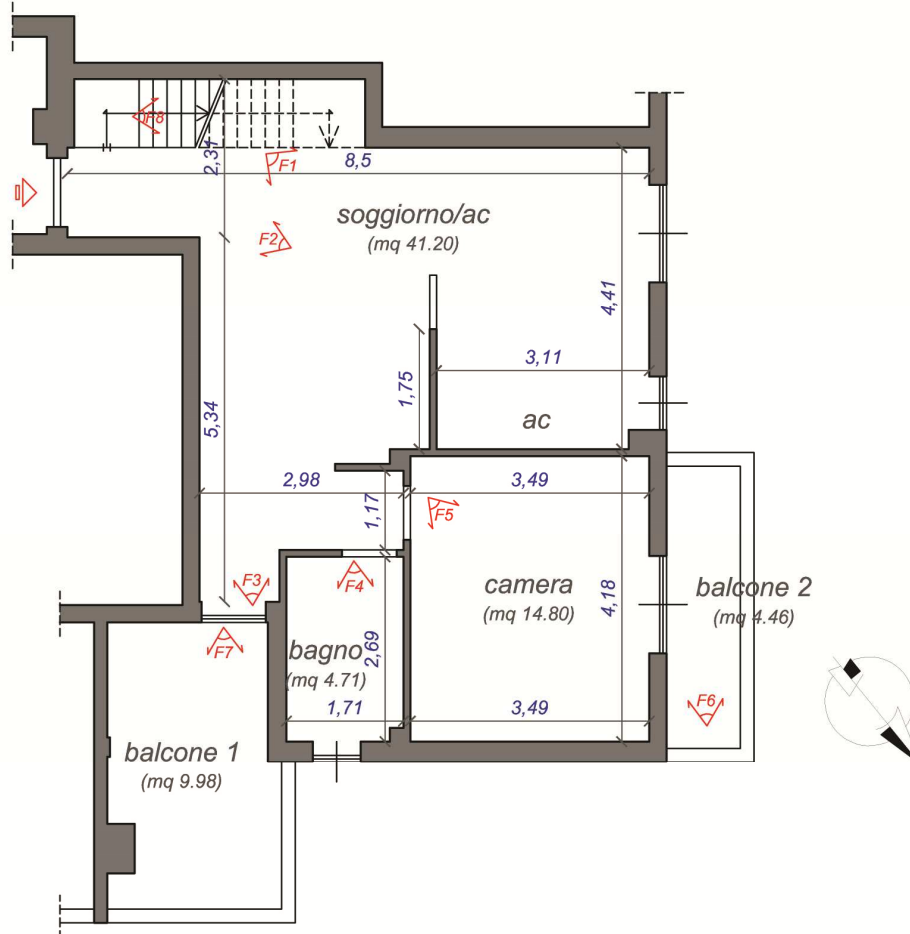

STATO DI FATTO
PIANTA PIANO 3
Soffitta - interno 14
scala 1:100

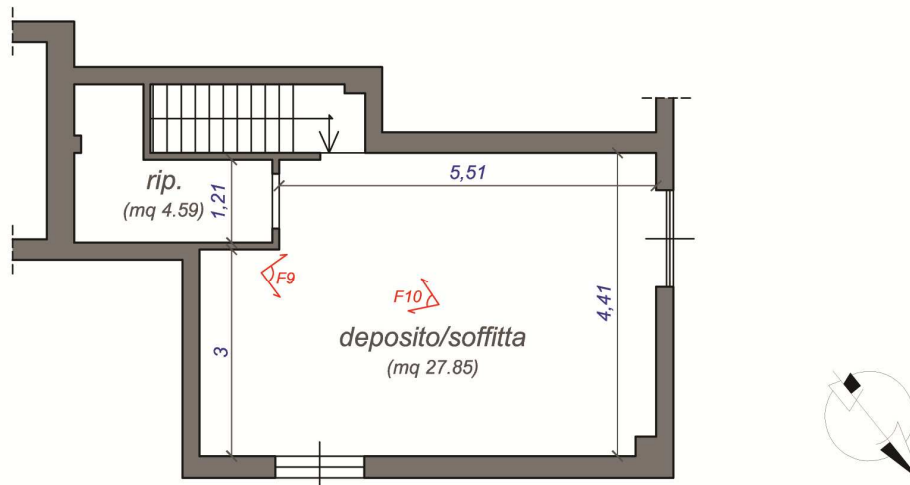

STATO DI FATTO
PIANTA PIANO INTERRATO
Box interno 40 - Cantina interno 8
scala 1:100

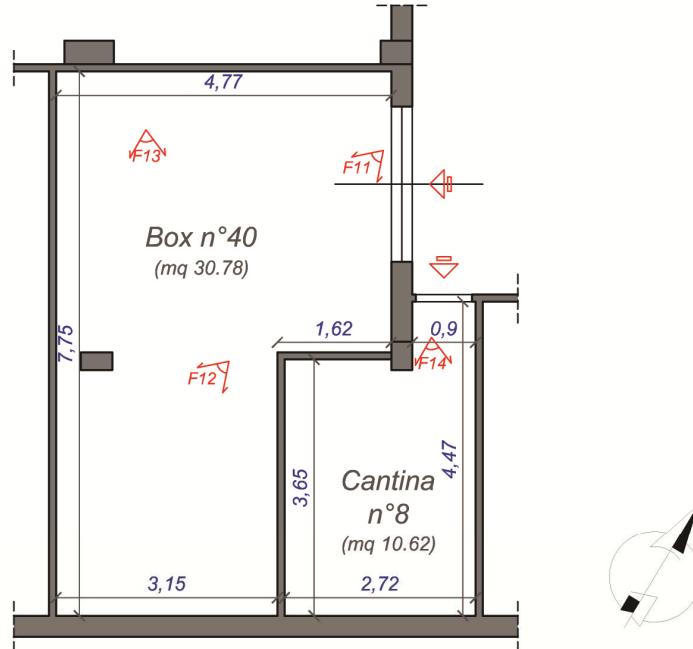

STATO DI FATTO
PIANTA PIANO INTERRATO
Posto Auto interno 1PA
scala 1:100

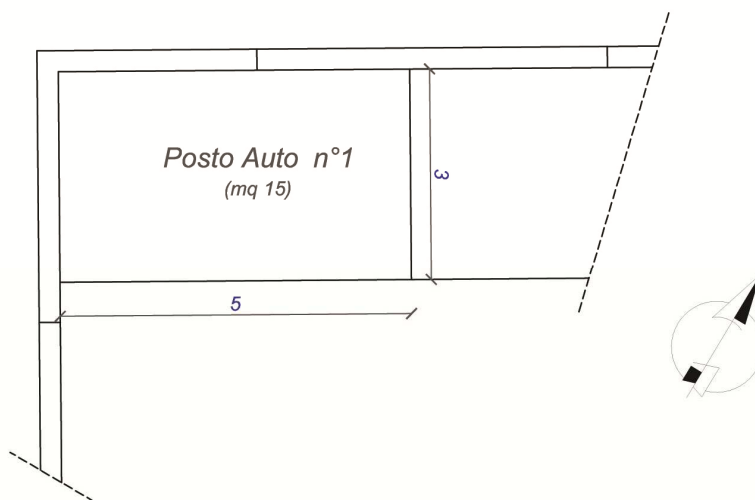



Vista dell'edificio di via Madonna dei Canneti n. 52/D Edificio F1 – scatto del 09/09/2025



Foto 1 - scatto del 09/09/2025 (Appartamento Piano Secondo interno 14)



Foto 2 - scatto del 09/09/2025 (Appartamento Piano Secondo interno 14)



Foto 3 - scatto del 09/09/2025
(Appartamento Piano Secondo interno 14)



Foto 4 - scatto del 09/09/2025
(Appartamento Piano Secondo interno 14)



Foto 5 - scatto del 09/09/2025
(Appartamento Piano Secondo interno 14)

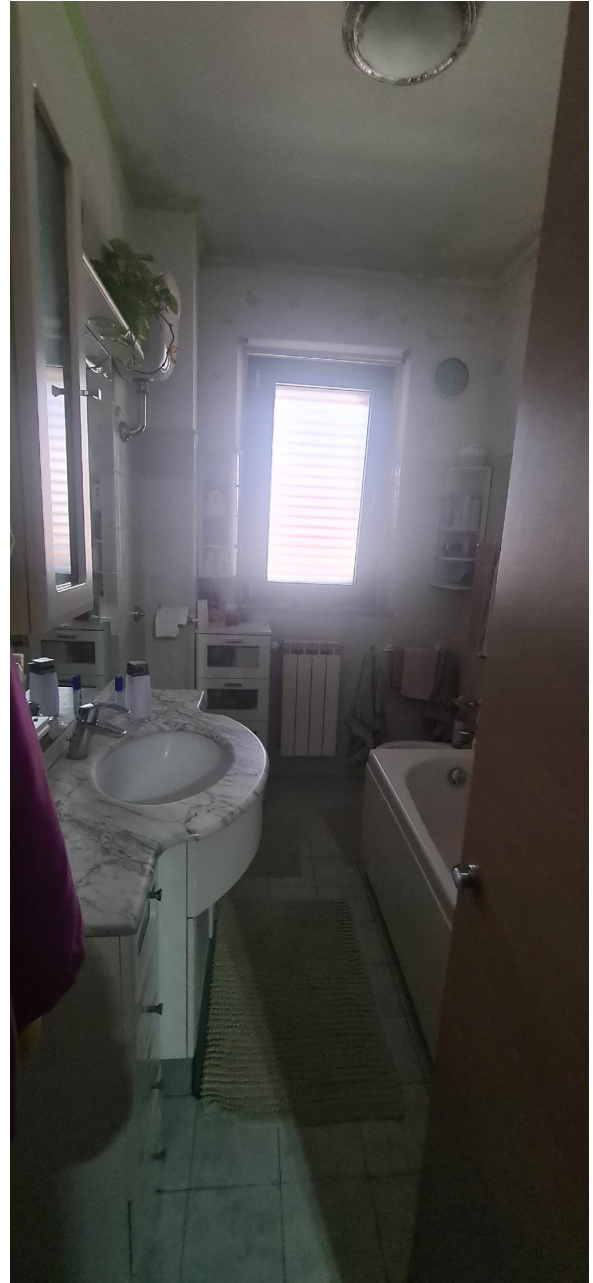

Foto 6 - scatto del 09/09/2025
(Appartamento Piano Secondo interno 14)



Foto 7 - scatto del 09/09/2025
(Appartamento Piano Secondo interno 14)



Foto 8 - scatto del 09/09/2025
(Appartamento Piano Secondo interno 14)

TRIBUNALE ORDINARIO DI CIVITAVECCHIA ESECUZIONI IMMOBILIARI
PROCEDURA IMMOBILIARE RGE 122/2025



Foto 9 - scatto del 09/09/2025 – (Soffitta Piano Terzo)

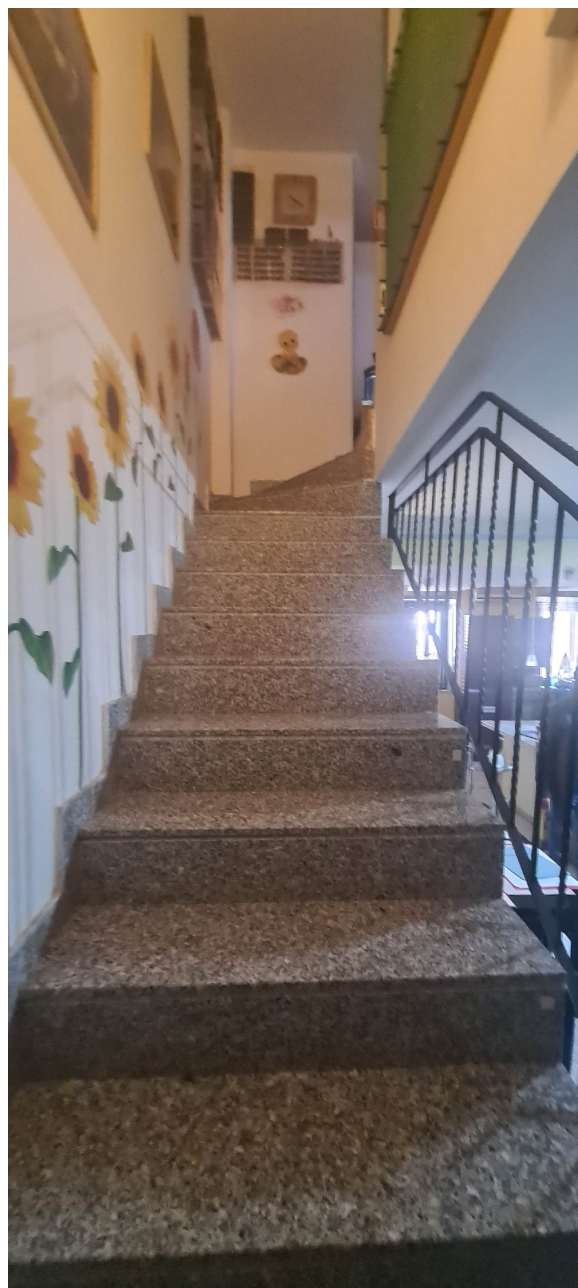

Foto 10 - scatto del 09/09/2025 – (Soffitta Piano Terzo)

TRIBUNALE ORDINARIO DI CIVITAVECCHIA ESECUZIONI IMMOBILIARI
PROCEDURA IMMOBILIARE RGE 122/2025



Foto 11 - scatto del 09/09/2025 - (Box Piano Interrato)

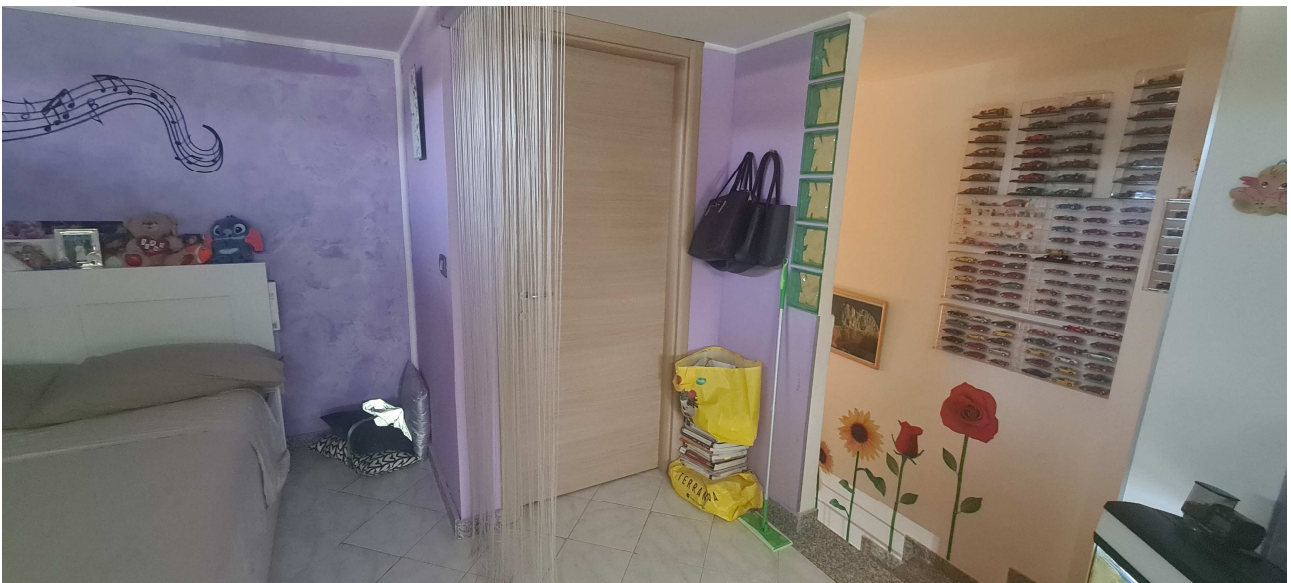

Foto 12 - scatto del 09/09/2025 - (Box Piano Interrato)

TRIBUNALE ORDINARIO DI CIVITAVECCHIA ESECUZIONI IMMOBILIARI
PROCEDURA IMMOBILIARE RGE 122/2025



Foto 13 - scatto del 09/09/2025 - (Box Piano Interrato)

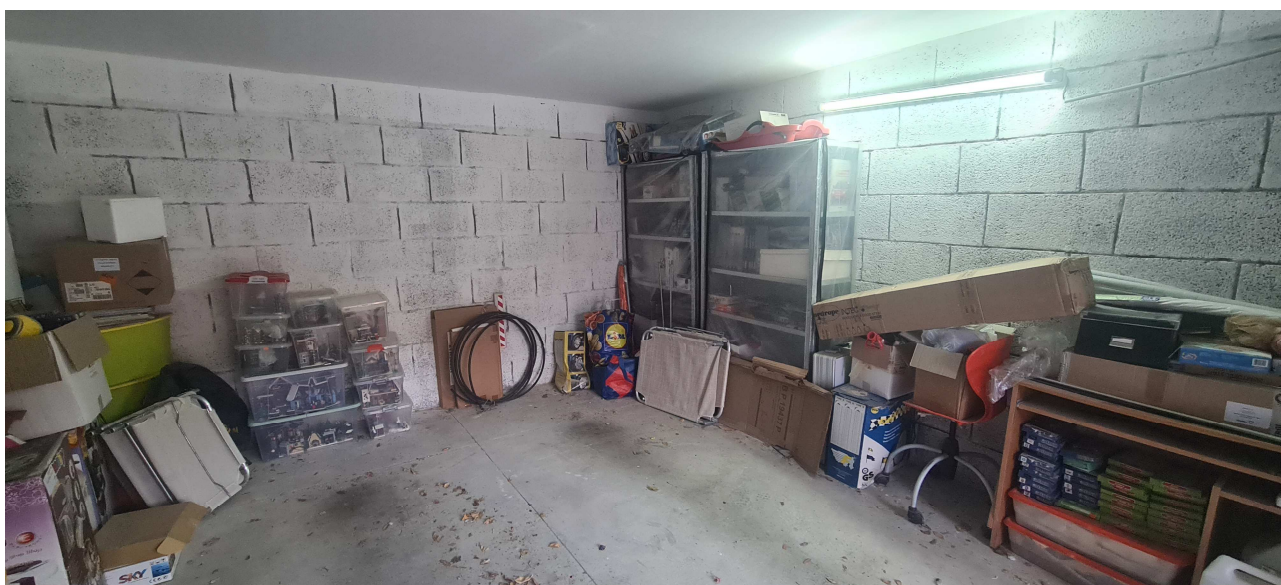

Foto 14 - scatto del 09/09/2025 - (Magazzino Piano Interrato)