

LOTTO 1 - Immobile A (p.1)
Comune di Cerignola - Via dei Tulipani snc
Unità immobiliare in p.S1-T-1-2 (F. 279 p.lla 571 sub.6)
Porzione unità immobiliare in p.1

Allegato n. 12
Tribunale di Foggia
P.E. Imm. n. 290/2020

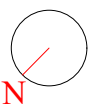
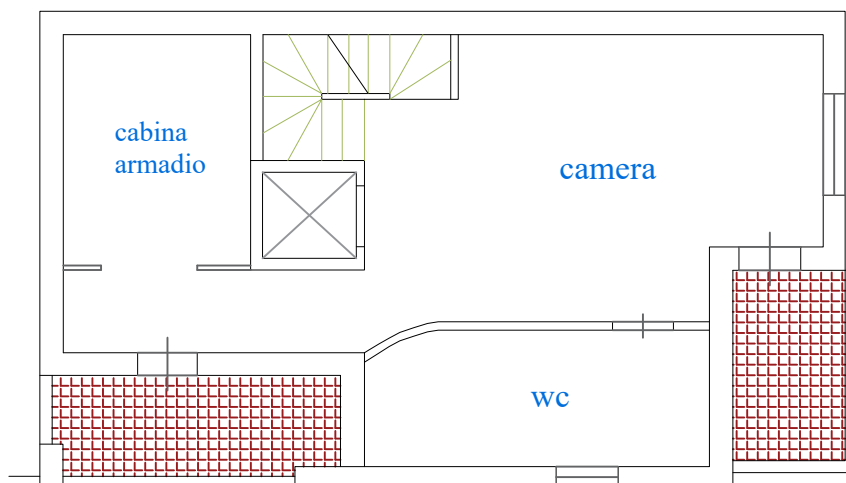

scala 1/100

C.T.U.: Ing. Francesco Paolo PADALINO



LOTTO 1 - Immobile A (p.2)
Comune di Cerignola - Via dei Tulipani snc
Unità immobiliare in p.S1-T-1-2 (F. 279 p.lla 571 sub.6)
Porzione unità immobiliare in p.2

Allegato n. 12
Tribunale di Foggia
P.E. Imm. n. 290/2020

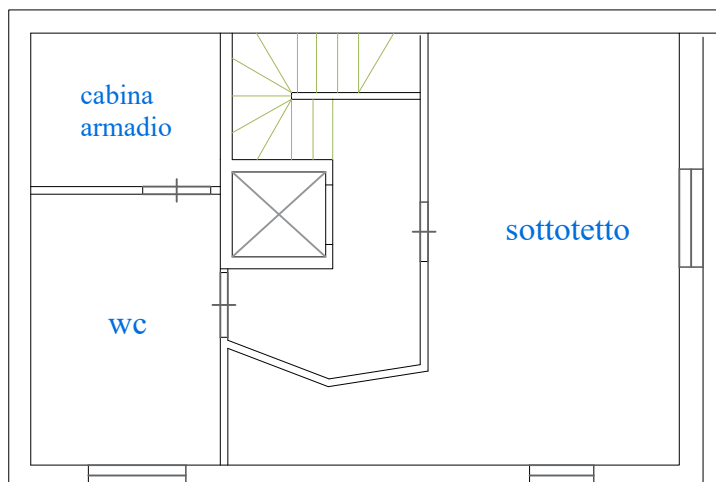

LOTTO 1 - Immobile A (p.S1)

Comune di Cerignola - Via dei Tulipani snc

Unità immobiliare in p.S1-T-1-2 (F. 279 p.lla 571 sub.6)

Porzione unità immobiliare in p.S1

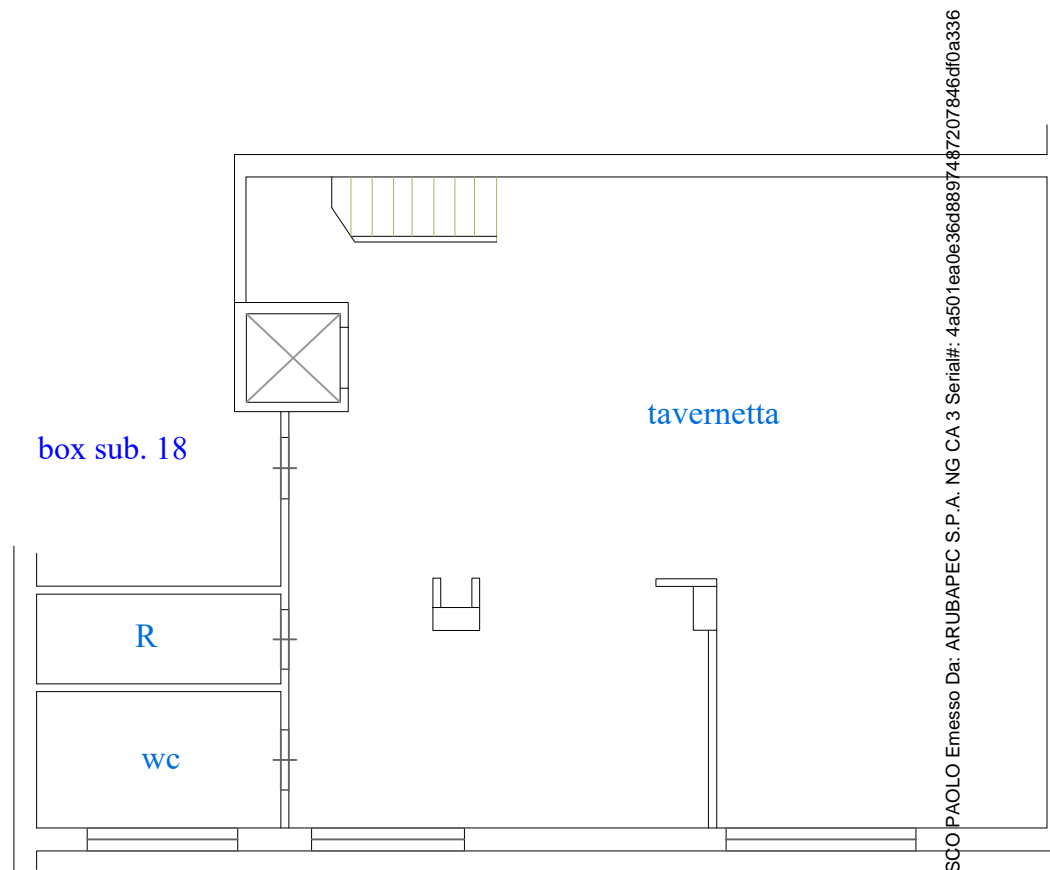

Firmato Da: PADALINO FRANCESCO PAOLO Emesso Da: ARUBAPEC S.P.A. NG CA 3 Serial#: 4a501ea0e36d8897487207846df0a336

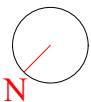

scala 1/100

C.T.U.: Ing. Francesco Paolo PADALINO



LOTTO 1 - Immobile B
Comune di Cerignola - Via dei Tulipani snc
Piano S.1 (F. 279 p.lla 571 sub.18)
Locale box in p.S1

Allegato n. 12
Tribunale di Foggia
P.E. Imm. n. 290/2020

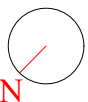
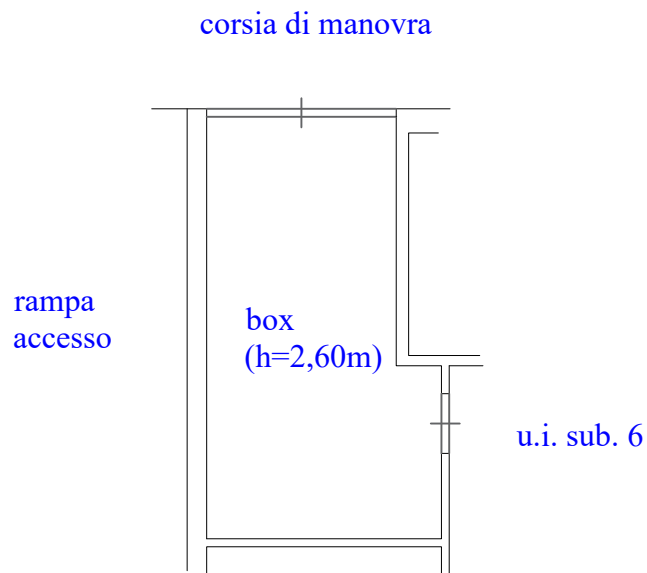

scala 1/100

C.T.U.: Ing. Francesco Paolo PADALINO



LOTTO 2 - Immobile C (p.S1)
Comune di Cerignola - Via dei Tulipani snc
Unità Immobiliare in p.S1-T (F. 279 p.lla 571 sub.19)
Porzione unità immobiliare in p.S1

Allegato n. 13
Tribunale di Foggia
P.E. Imm. n. 290/2020

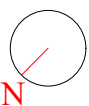
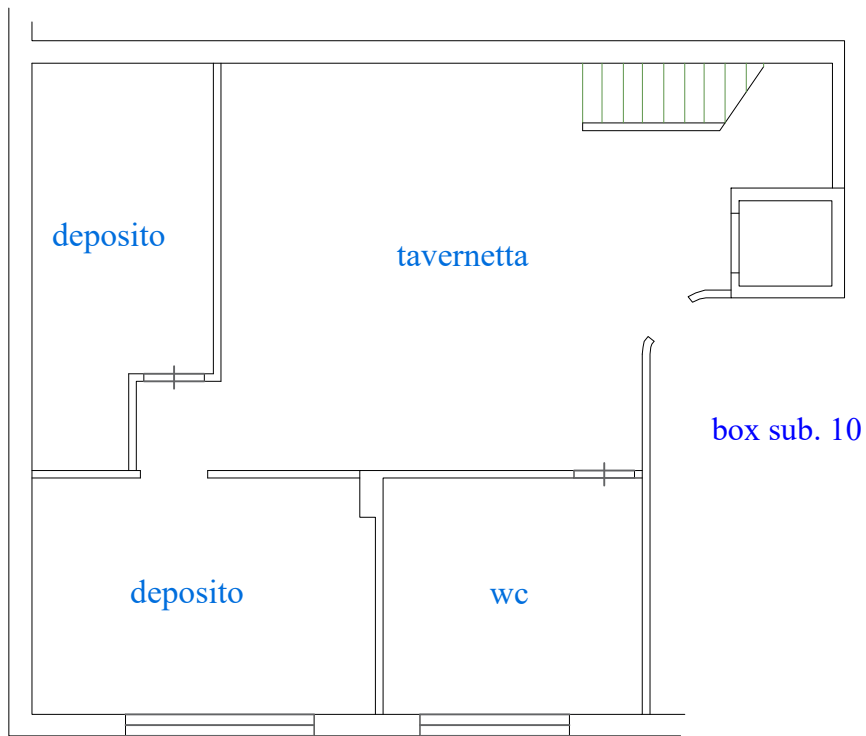

scala 1/100

C.T.U.: Ing. Francesco Paolo PADALINO



LOTTO 2 - Immobile C (p.T)

Comune di Cerignola - Via dei Tulipani snc

Unità Immobiliare in p.S1-T (F. 279 p.lla 571 sub.19)

Porzione unità immobiliare in p.T

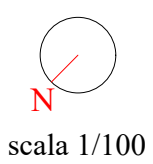
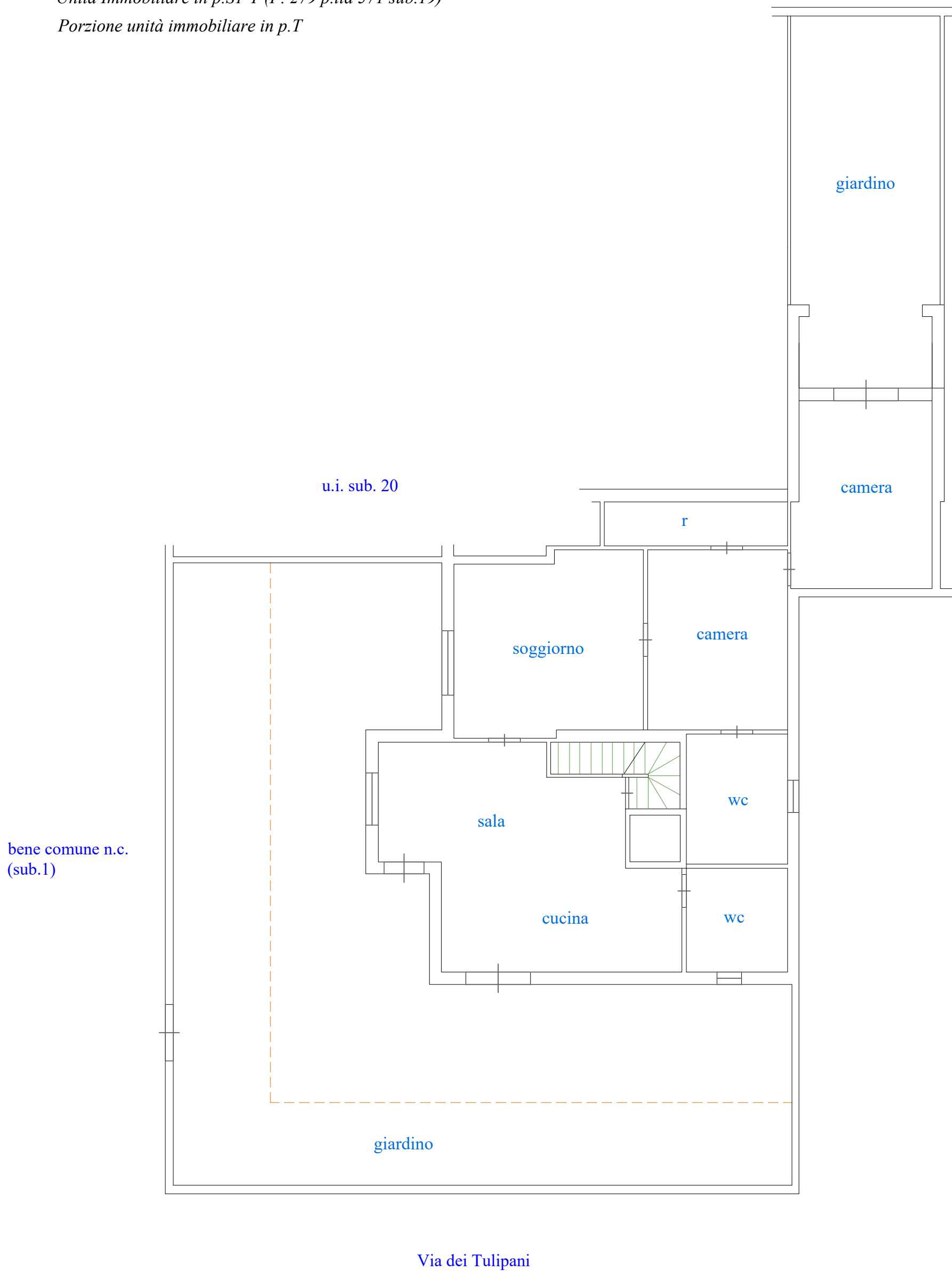

LOTTO 2 - Immobile D
Comune di Cerignola - Via dei Tulipani snc
Unità Immobiliare in p.SI (F. 279 p.lla 571 sub.10)
Locale box in p.SI

Allegato n. 13
Tribunale di Foggia
P.E. Imm. n. 290/2020

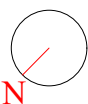
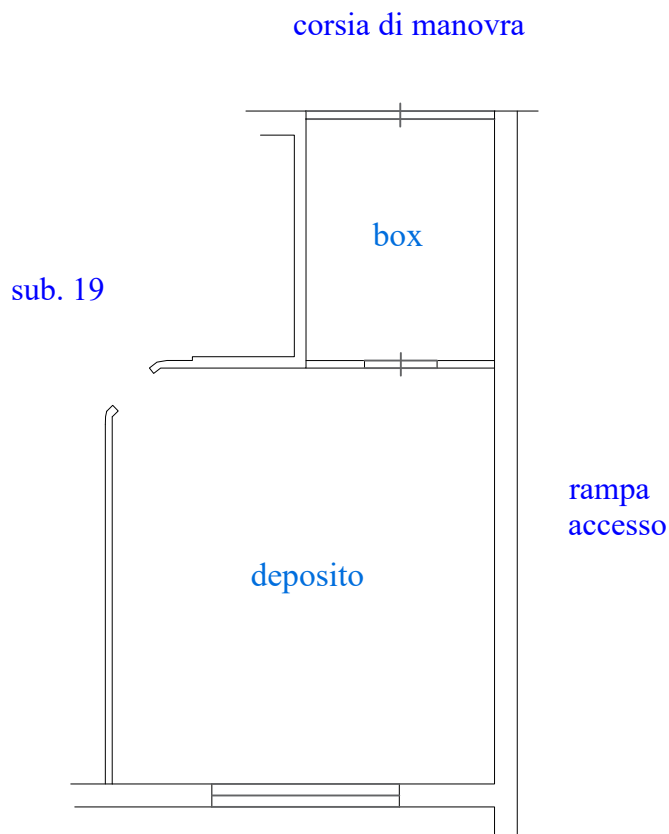

scala 1/100

C.T.U.: Ing. Francesco Paolo PADALINO



LOTTO 3 - Immobile E (p.1)
Comune di Cerignola - Via dei Tulipani snc
Unità Immobiliare in p.T-1-2 (F. 279 p.lla 571 sub.20)
Porzione unità immobiliare in p.1

Allegato n. 14
Tribunale di Foggia
P.E. Imm. n. 290/2020

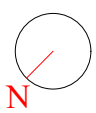
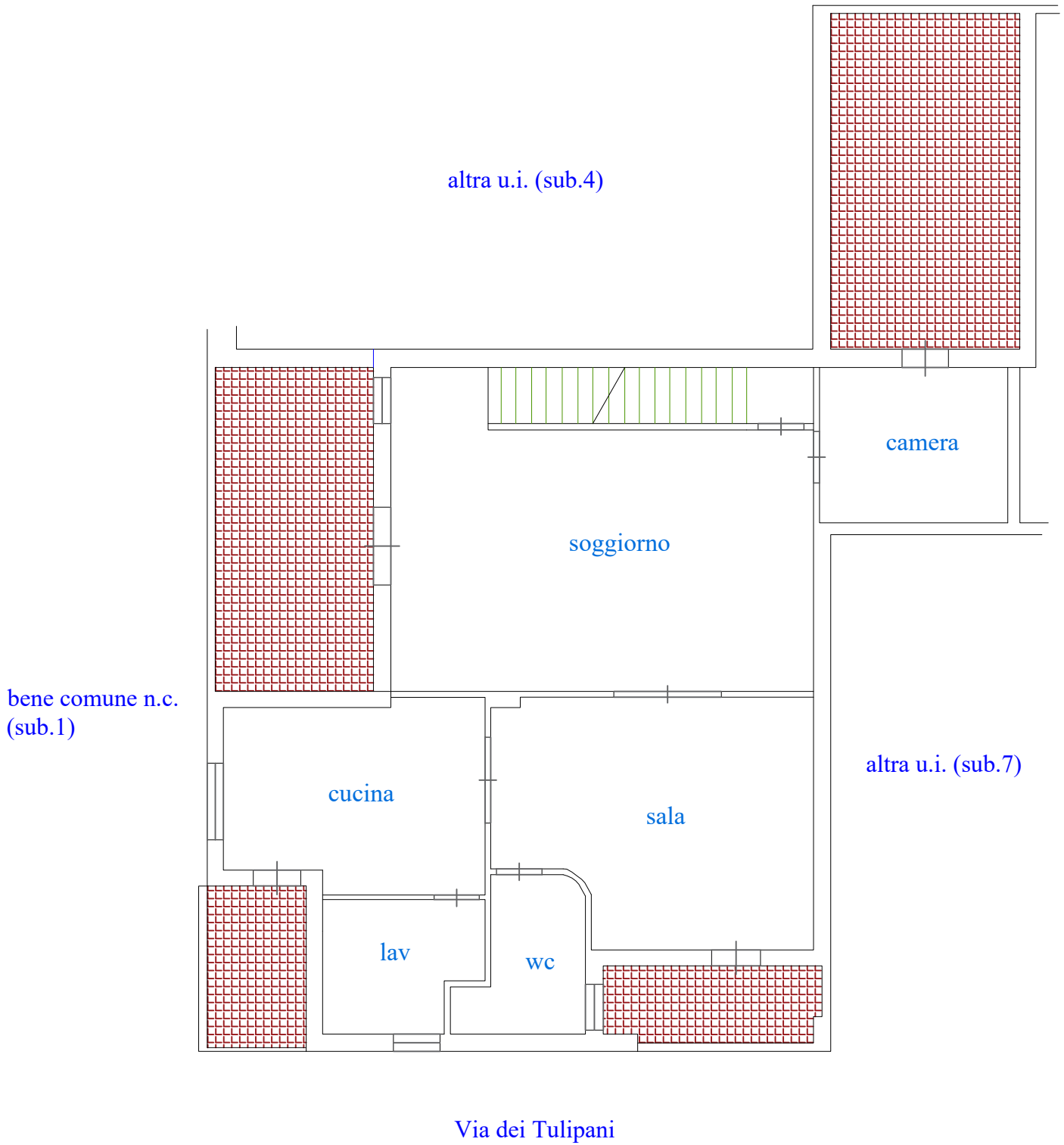

scala 1/100

C.T.U.: Ing. Francesco Paolo PADALINO

Firmato Da: PADALINO FRANCESCO PAOLO Emesso Da: ARUBAPEC S.P.A. NG CA 3 Serial#: 4a501ea0e36d8897487207846df0a336



LOTTO 3 - Immobile E (p.T)
Comune di Cerignola - Via dei Tulipani snc
Unità Immobiliare in p.T-1-2 (F. 279 p.lla 571 sub.20)
Porzione unità immobiliare in p.T

Allegato n. 14
Tribunale di Foggia
P.E. Imm. n. 290/2020

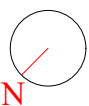
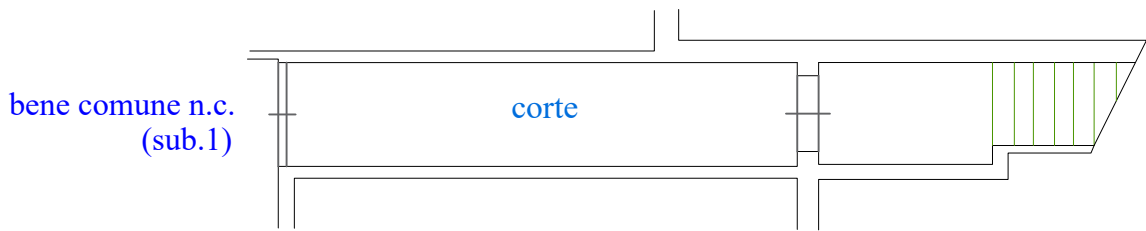

scala 1/100

C.T.U.: Ing. Francesco Paolo PADALINO



LOTTO 3 - Immobili F-G
Comune di Cerignola - Via dei Tulipani snc
Unità Immobiliari in p.SI (F. 279 p.lla 571 sub.11-12)
Locali box in p.SI

Allegato n. 14
Tribunale di Foggia
P.E. Imm. n. 290/2020

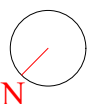
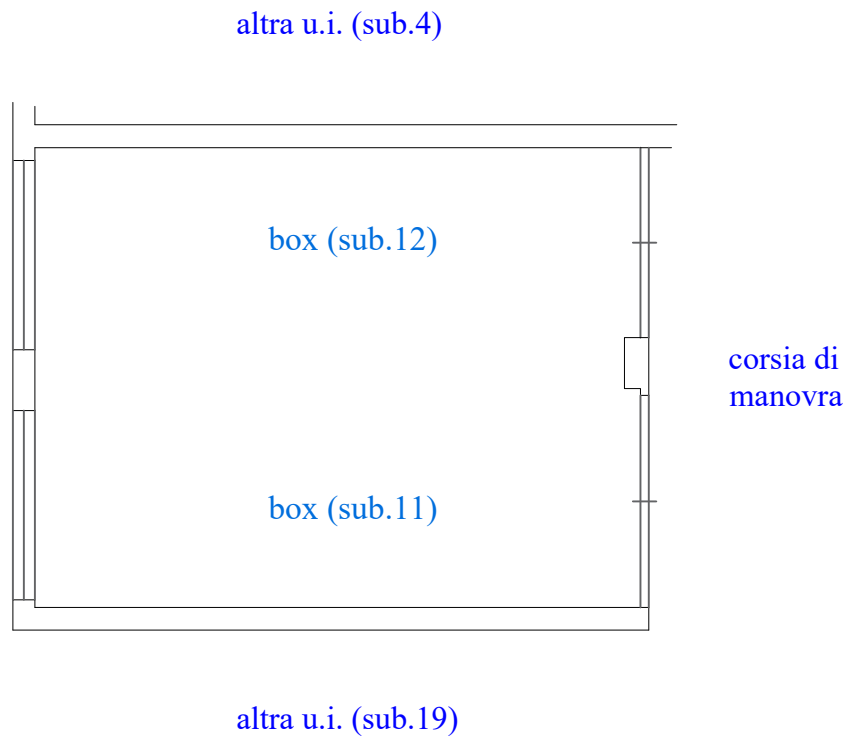

scala 1/100

C.T.U.: Ing. Francesco Paolo PADALINO



LOTTO 4 - Immobile H
Comune di Cerignola - Via dei Tulipani snc
Unità Immobiliare in p.SI (F. 279 p.lla 571 sub.14)
Locale box in p.SI

Allegato n. 15
Tribunale di Foggia
P.E. Imm. n. 290/2020

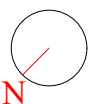
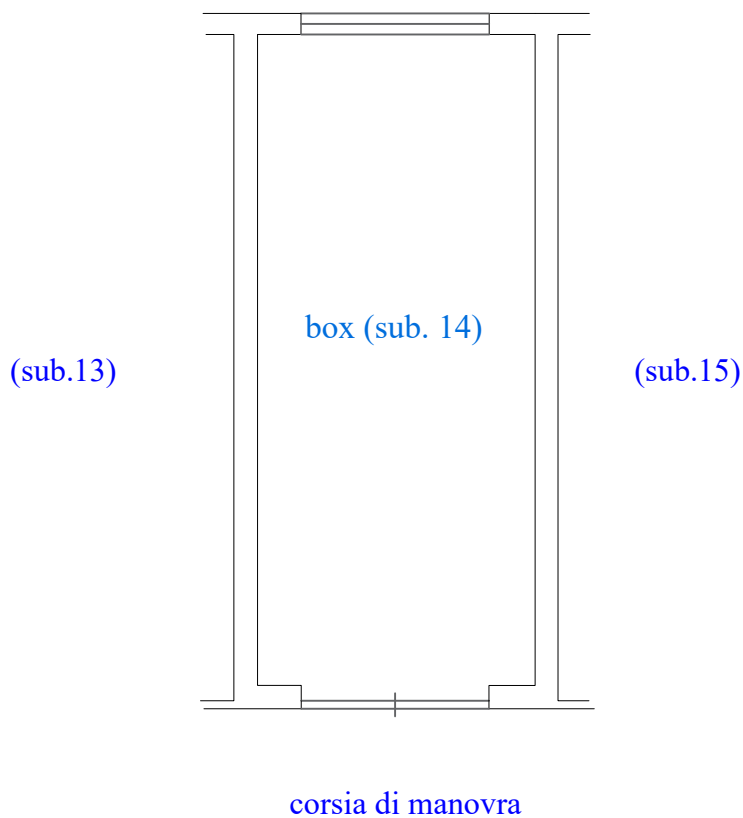

scala 1/100

C.T.U.: Ing. Francesco Paolo PADALINO

Firmato Da: PADALINO FRANCESCO PAOLO Emesso Da: ARUBAPEC S.P.A. NG CA 3 Serial#: 4a501ea0e36d8897487207846df0a336



LOTTO 5 - Immobile I
Comune di Cerignola - Via dei Tulipani snc
Unità Immobiliare in p.SI (F. 279 p.lla 571 sub.16)
Locale box in p.SI

Allegato n. 16
Tribunale di Foggia
P.E. Imm. n. 290/2020

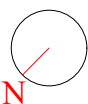
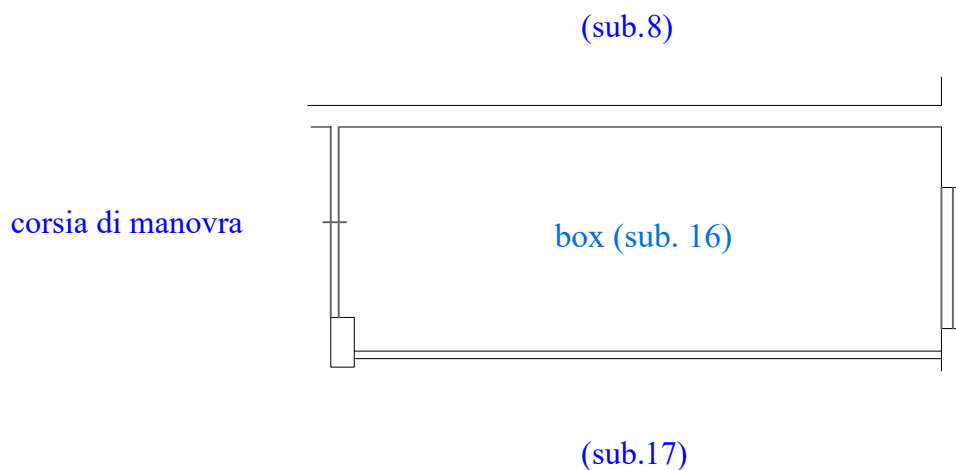

scala 1/100

C.T.U.: Ing. Francesco Paolo PADALINO

Firmato Da: PADALINO FRANCESCO PAOLO Emesso Da: ARUBAPEC S.P.A. NG CA 3 Serial#: 4a501ea0e36d8897487207846df0a336

