

P.E. 196/2025 - Tribunale di Genova
Immobile 2 - **box e cantina** (lotto unico)
Rilievo dello stato attuale

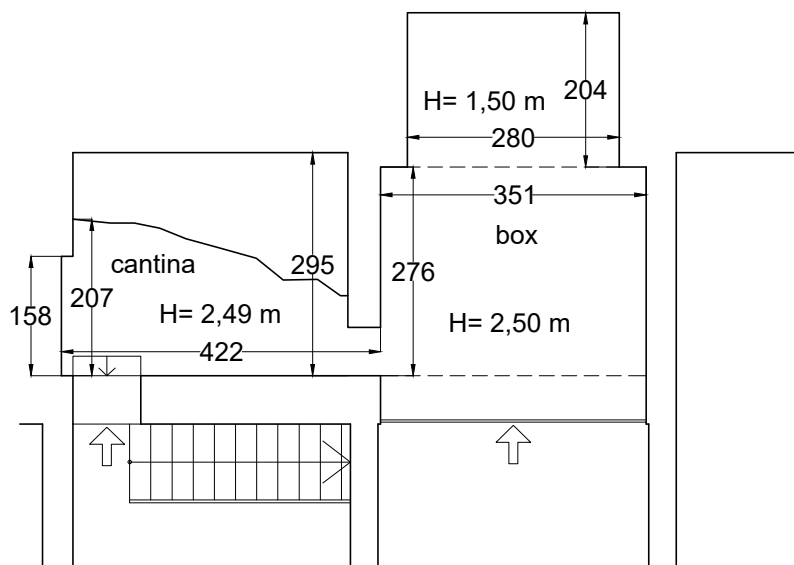

box e cantina - *scala 1:100*

P.E. 196/2025 - Tribunale di Genova
Immobile 2 - **box e ripostiglio** (lotto unico)
Sovrapposizione del rilievo sul progetto approvato
var. DIA 11 agosto 2010

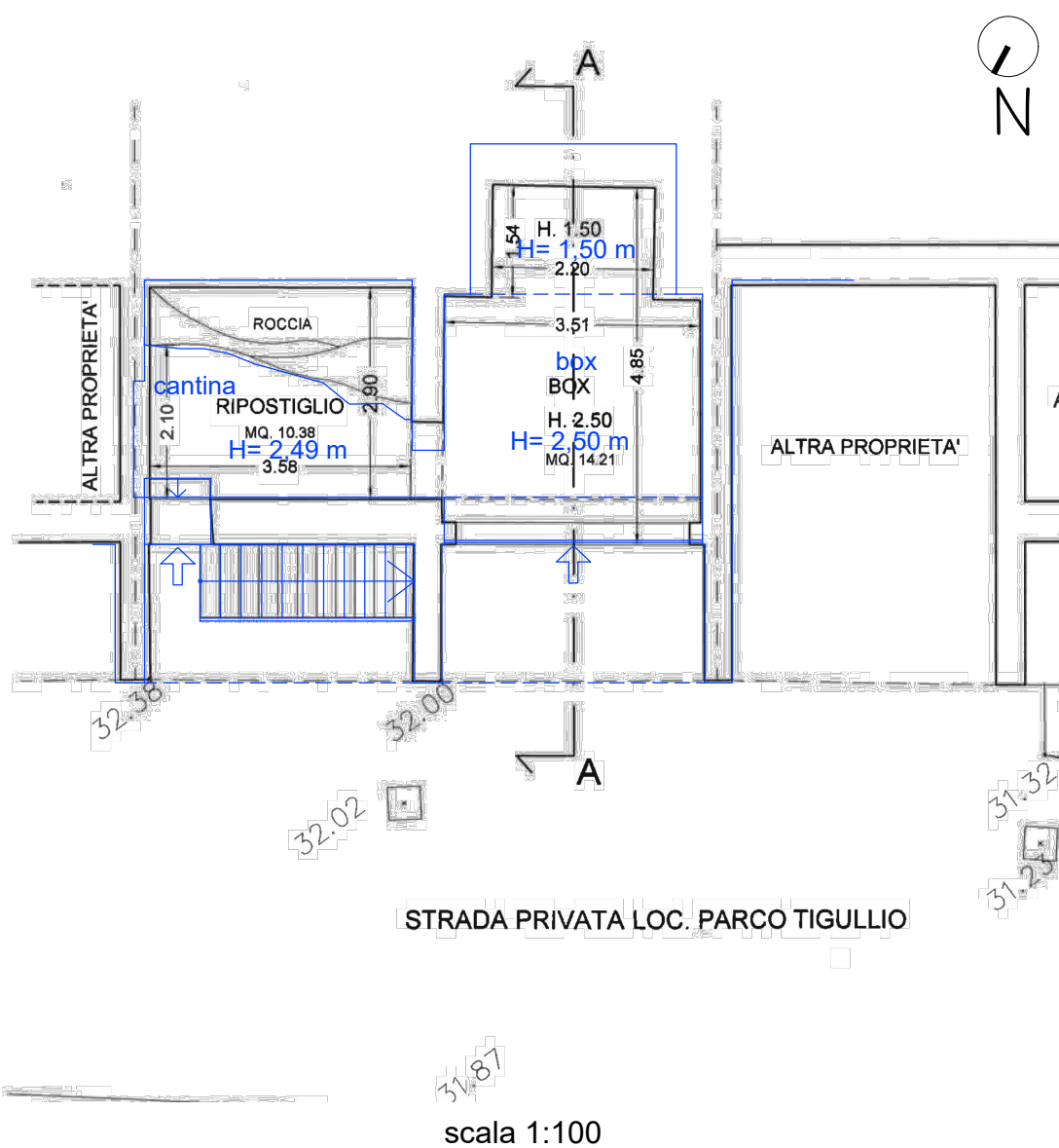

 In blu il rilievo dello stato attuale

P.E. 196/2025 - Tribunale di Genova
Immobile 2 - **box e cantina** (lotto unico)
Sovrapposizione del rilievo sulla planimetria catastale

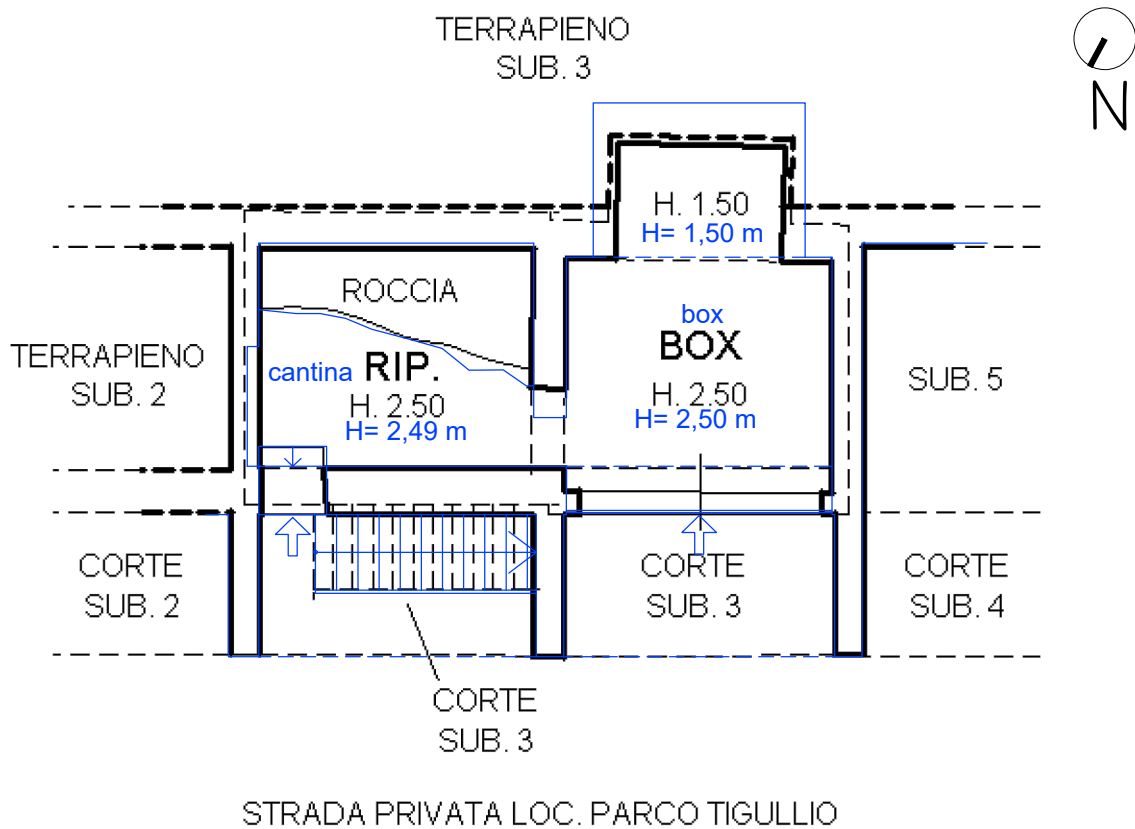

scala 1:100

 In blu il rilievo dello stato attuale