

**ALLEGATO**

**2**

**Rilievo Fotografico**

**LOTTO 1**

**NCEU GIOIA SANNITICA FOG. 3 P.LLA 5103 SUB 2 – 3**

**NCT FOG. 3 P.LLA 301 E P.LLA 240**



**Foto 1**



**Foto 2**



**Foto 3**



**Foto 4**



Ing. Flavio Toscano viale Santa Reparata, 54 81057 Teano (ce)  
fax 0823.875.174 cell.338.46.76.832 e-mail: info@flaviotoscano.it

**Esecuzione Immobiliare R.G.E. 209/2020 promossa da AQUI SPV SRL contro IANNETELLI BARBARA**



Certificazioni  
di competenza professionale.



Foto 5



Foto 6



Foto 7



Foto 8



Foto 9



Foto 10



Foto 11



Foto 12



Ing. Flavio Toscano viale Santa Reparata,54 81057 Teano (ce)  
fax 0823.875.174 cell.338.46.76.832 e-mail: info@flaviotoscano.it

**Esecuzione Immobiliare R.G.E. 209/2020 promossa da AQUI SPV SRL contro IANNETELLI BARBARA**

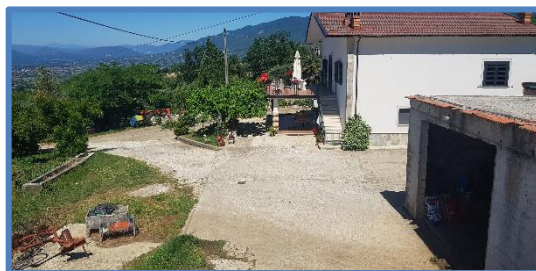

Certificazioni  
di professionisti



Foto 13



Foto 14



Foto 15

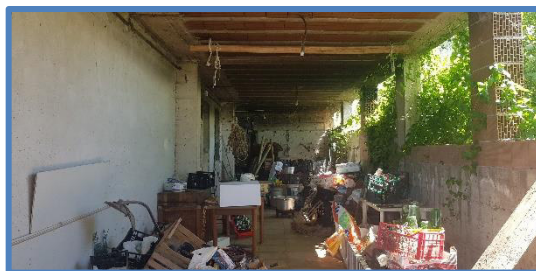

Foto 16



Foto 17



Foto 18



Foto 19



Foto 20

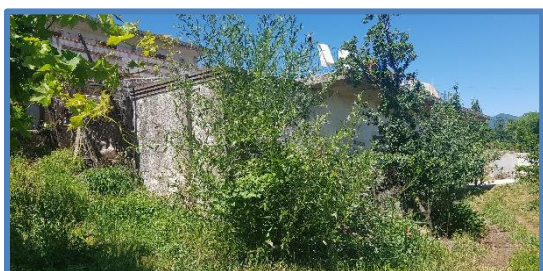

Ing. Flavio Toscano viale Santa Reparata, 54 81057 Teano (ce)  
fax 0823.875.174 cell.338.46.76.832 e-mail: info@flaviotoscana.it

Esecuzione Immobiliare R.G.E. 209/2020 promossa da AQUI SPV SRL contro IANNETELLI BARBARA



Certificazioni  
di professionisti



Foto 21



Foto 22



Foto 23



Foto 24

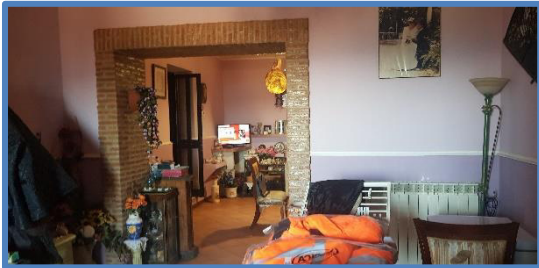

Foto 25



Foto 26

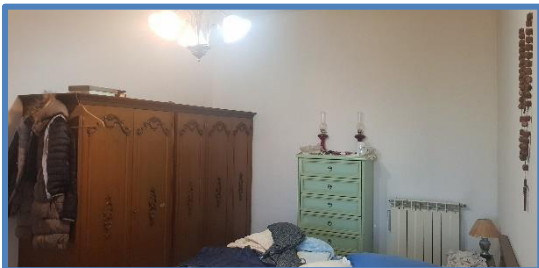

Foto 27

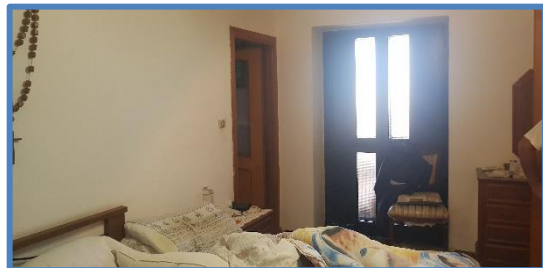

Foto 28



Ing. Flavio Toscano viale Santa Reparata, 54 81057 Teano (ce)  
fax 0823.875.174 cell.338.46.76.832 e-mail: info@flaviotoscano.it

**Esecuzione Immobiliare R.G.E. 209/2020 promossa da AQUI SPV SRL contro IANNETELLI BARBARA**





Foto 29



Foto 30



Ing. Flavio Toscano viale Santa Reparata,54 81057 Teano (ce)  
fax 0823.875.174 cell.338.46.76.832 e-mail: info@flaviotoscano.it

**Esecuzione Immobiliare R.G.E. 209/2020 promossa da AQUI SPV SRL contro IANNETELLI BARBARA**



**ALLEGATO**

**3**

**Elaborati Grafici**

# RILIEVO DELLO STATO DEI LUOGHI

DATI CATASTALI: COMUNE DI GIOIA SANNITICA, FOGLIO 3 P.LLA 5103 SUB 2-3

 fabbricato - SUB 2

 fabbricato - SUB 3

## PIANO TERRA

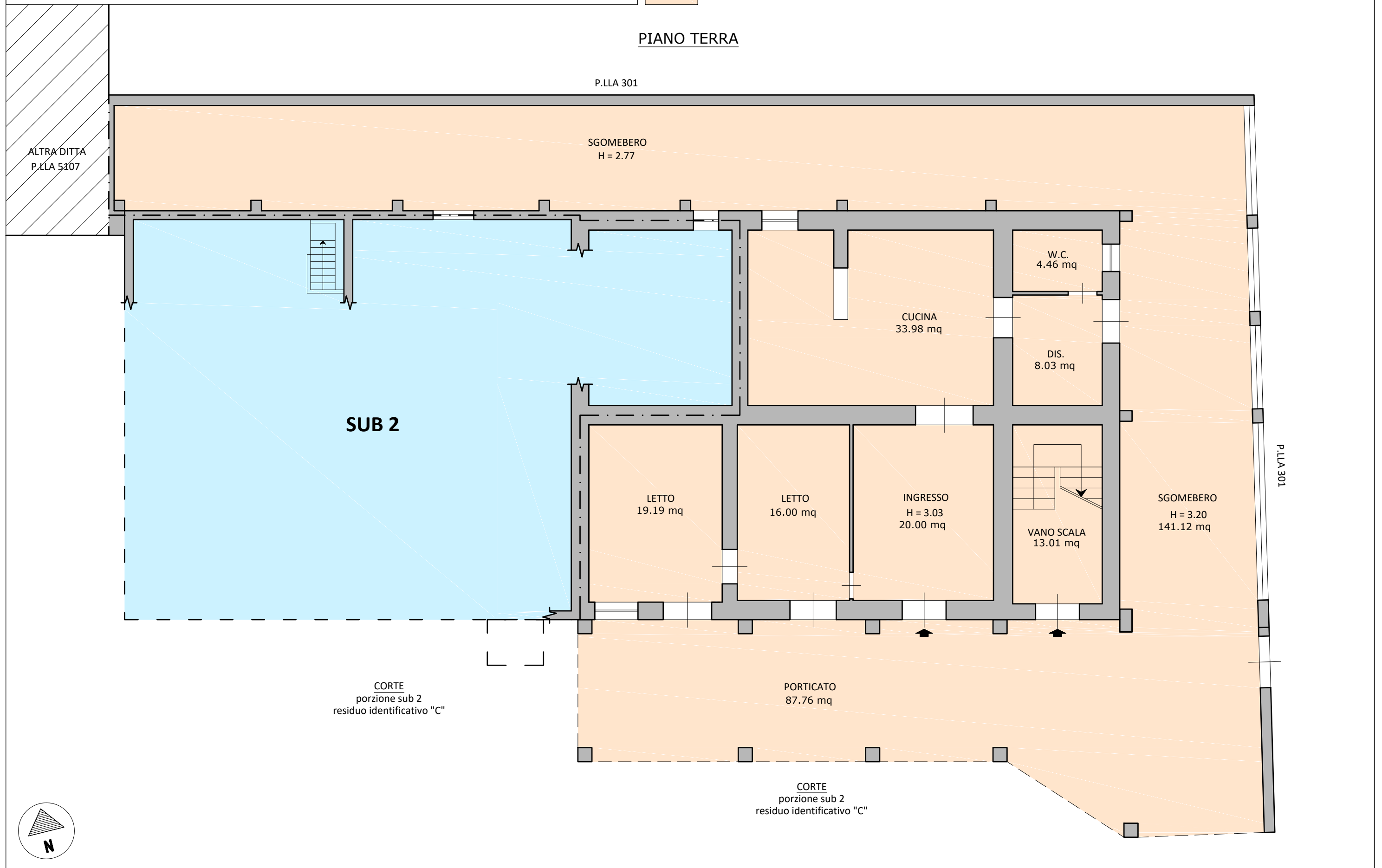



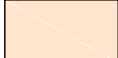

**VERIFICA CONFORMITÀ CATASTALE**

DATI CATASTALI: COMUNE DI GIOIA SANNITICA, FOGLIO 3 P.LLA 5103 SUB 2-3

-  fabbricato - SUB 2
-  fabbricato - SUB 3

- PLANIMETRIA DI RILIEVO 
- PLANIMETRIA CATASTALE 
- DIFFORMITÀ 

**PIANTA PIANO TERRA**

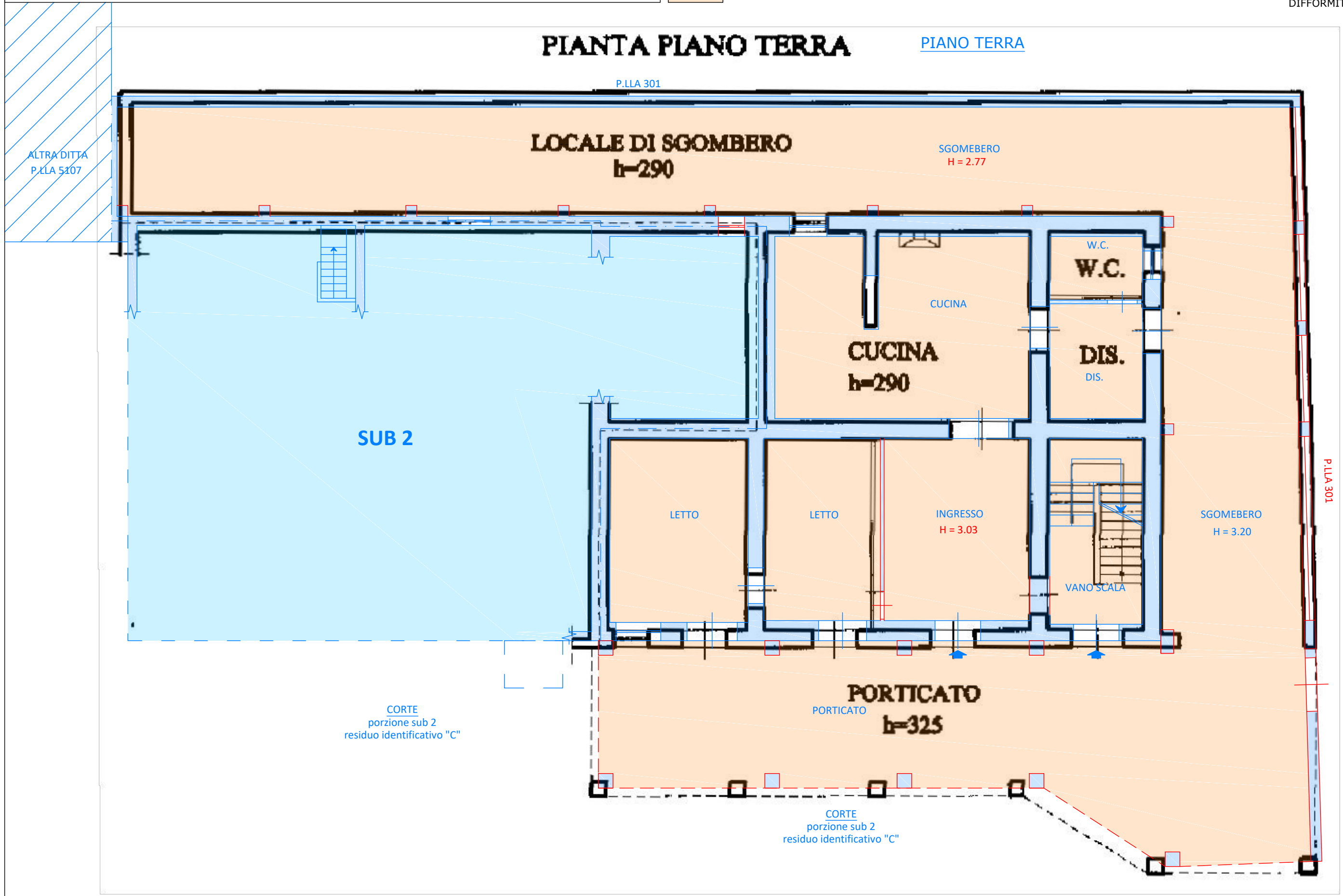

PIANO TERRA

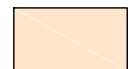

**VERIFICA CONFORMITÀ URBANISTICA**

DATI CATASTALI: COMUNE DI GIOIA SANNITICA, FOGLIO 3 P.LLA 5103 SUB 2-3

 fabbricato - SUB 2  
 fabbricato - SUB 3

PLANIMETRIA DI RILIEVO   
PLANIMETRIA TITOLO EDILIZIO   
DIFFORMITÀ 

STRALCIO GRAFICI C.E. N°51/99

**PIANO TERRA**

P.LLA 301

ALTRA DITTA  
P.LLA 5107

volumetria non assentita

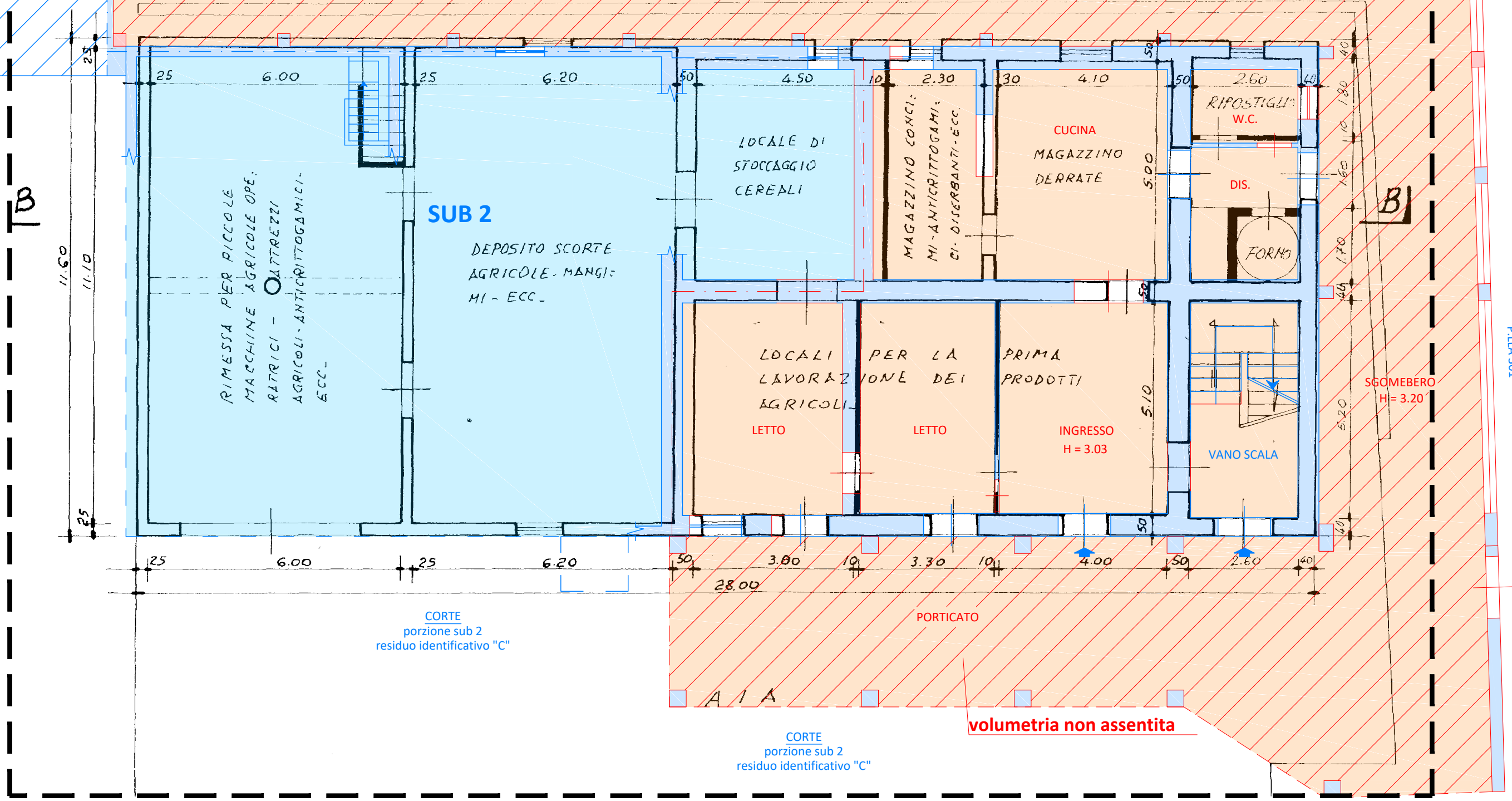

# RILIEVO DELLO STATO DEI LUOGHI

DATI CATASTALI: COMUNE DI GIOIA SANNITICA, FOGLIO 3 P.LLA 5103 SUB 2-3

 fabbricato - SUB 2

 fabbricato - SUB 3

## PIANO PRIMO

**superficie da destinare ad attività agricola**

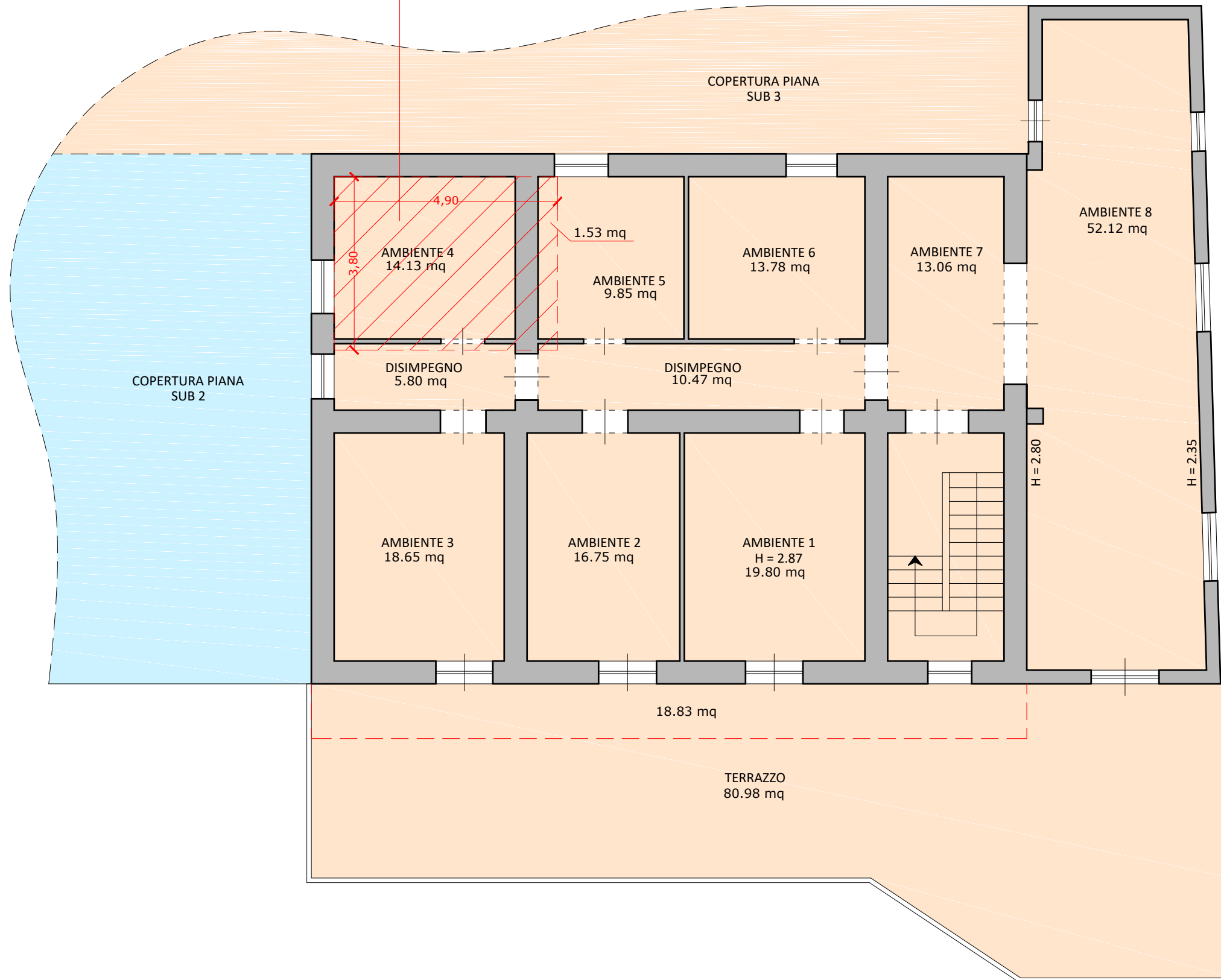

# VERIFICA CONFORMITÀ CATASTALE

DATI CATASTALI: COMUNE DI GIOIA SANNITICA, FOGLIO 3 P.LLA 5103 SUB 2-3

 fabbricato - SUB 2

 fabbricato - SUB 3

PLANIMETRIA DI RILIEVO 

PLANIMETRIA CATASTALE 

DIFFORMITÀ 

## PIANO PRIMO

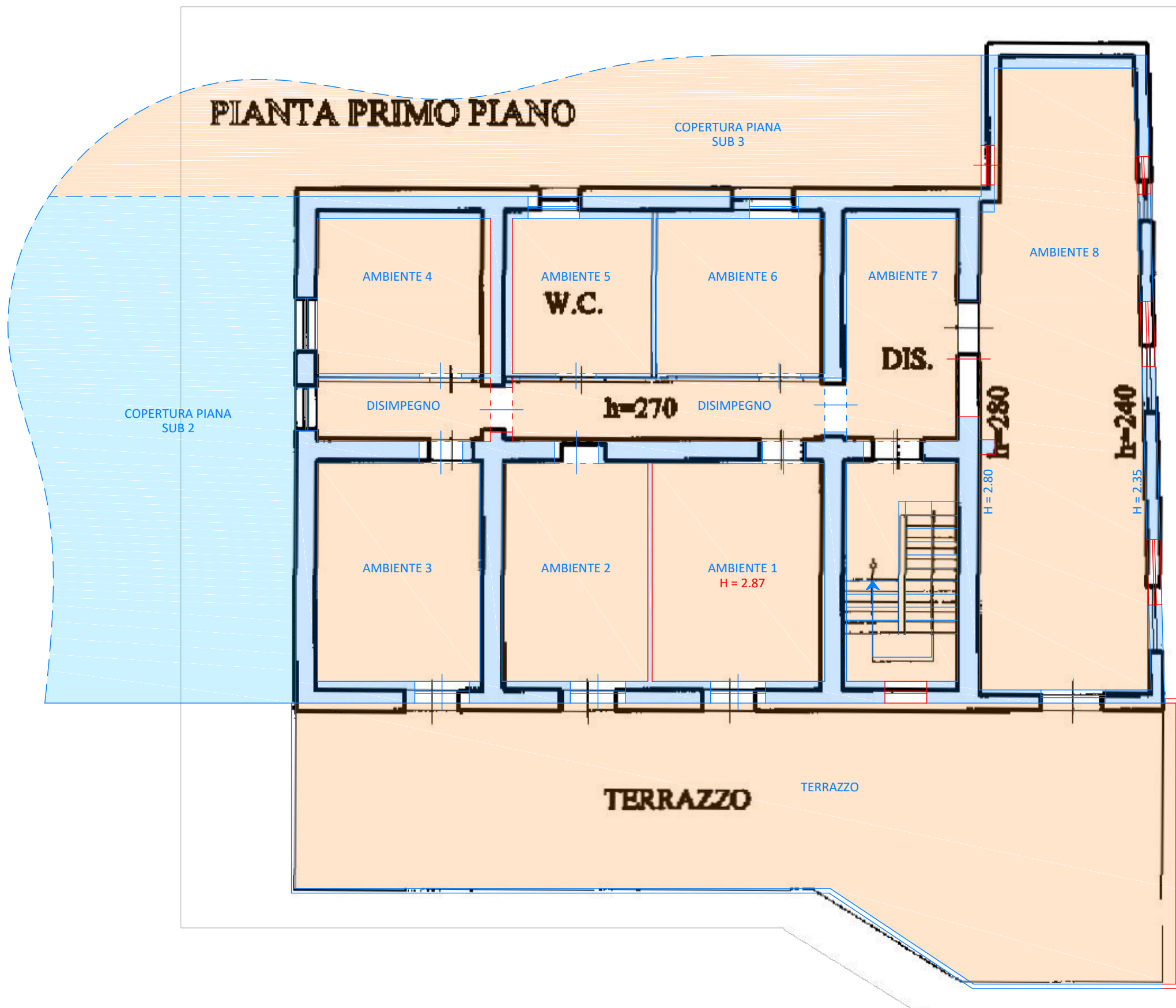

**VERIFICA CONFORMITÀ URBANISTICA**

DATI CATASTALI: COMUNE DI GIOIA SANNITICA, FOGLIO 3 P.LLA 5103 SUB 2-3

- fabbricato - SUB 2**
- fabbricato - SUB 3**

- PLANIMETRIA DI RILIEVO
- PLANIMETRIA TITOLO EDILIZIO
- DIFFORMITÀ

**PIANO PRIMO**

**superficie da destinare ad attività agricola**

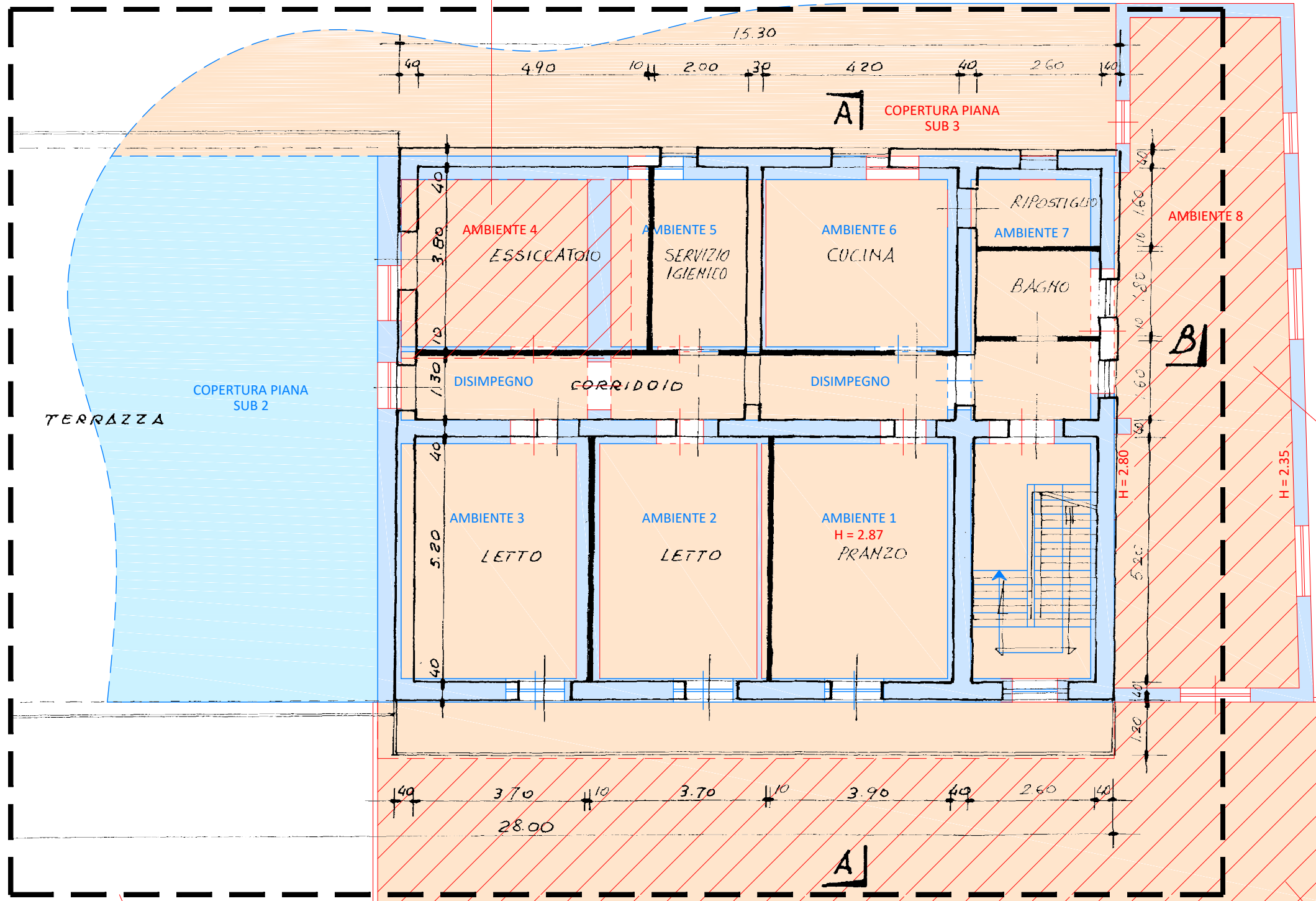

**volumetria non assentita**

**STRALCIO GRAFICI C.E. N°51/99**

**superficie non assentita**



# RILIEVO DELLO STATO DEI LUOGHI

DATI CATASTALI: COMUNE DI GIOIA SANNITICA, FOGLIO 3 P.LLA 5103 SUB 2-3

 fabbricato - SUB 2

 fabbricato - SUB 3

PIANO TERRA

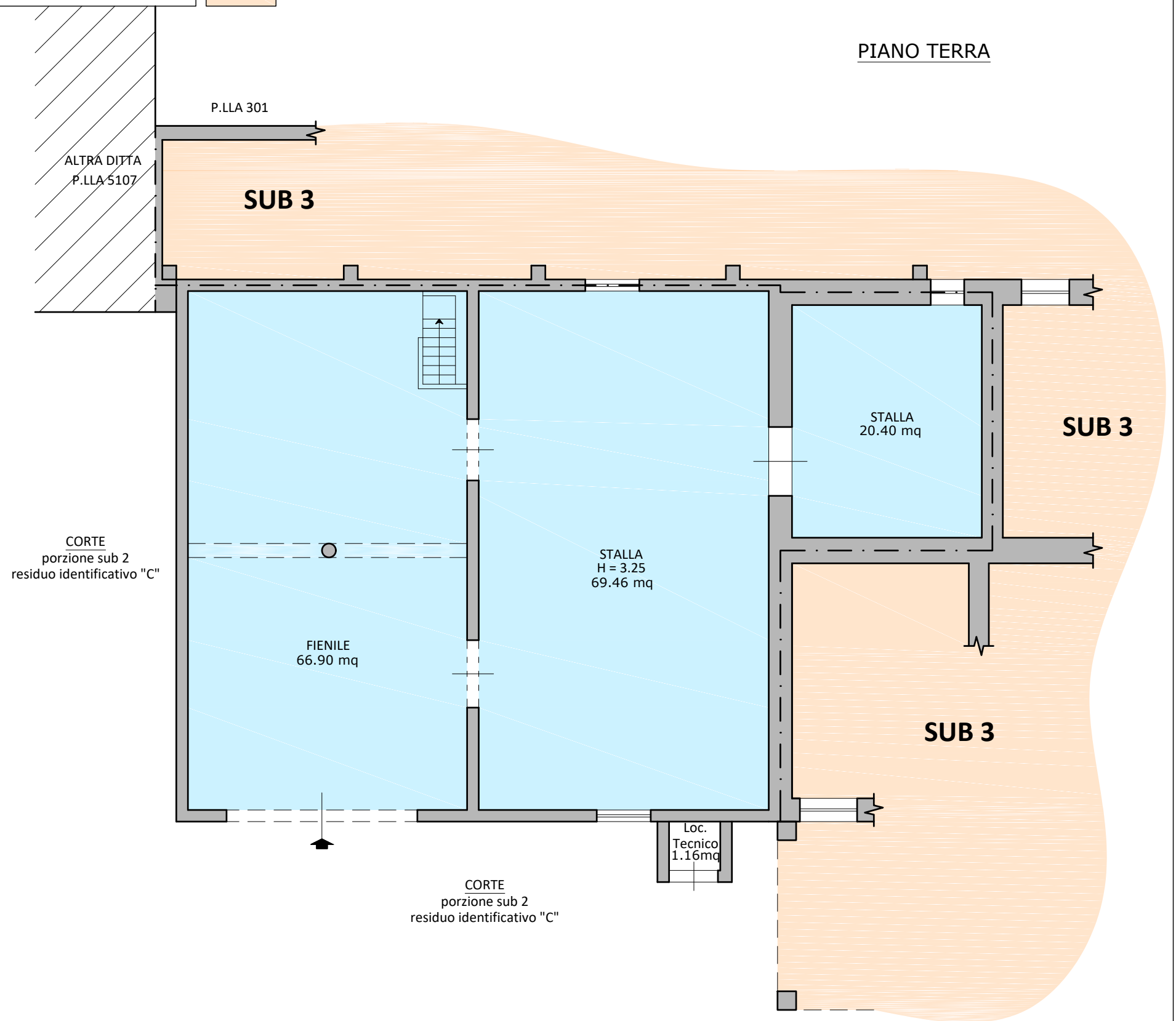
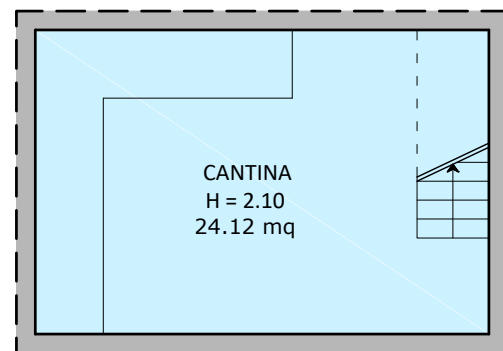

PIANO INTERRATO

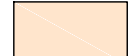

# VERIFICA CONFORMITÀ CATASTALE

DATI CATASTALI: COMUNE DI GIOIA SANNITICA, FOGLIO 3 P.LLA 5103 SUB 2-3

-  fabbricato - SUB 2
-  fabbricato - SUB 3

- PLANIMETRIA DI RILIEVO 
- PLANIMETRIA CATASTALE 
- DIFFORMITÀ 

## PIANO SEMINTERRATO

PIANO INTERRATO

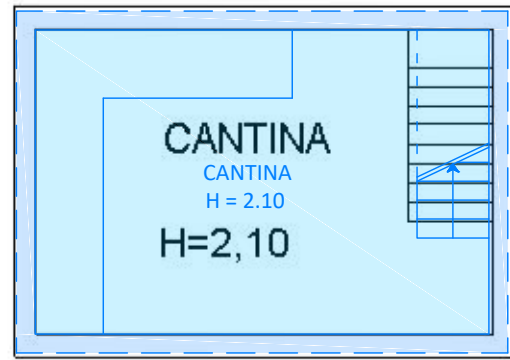

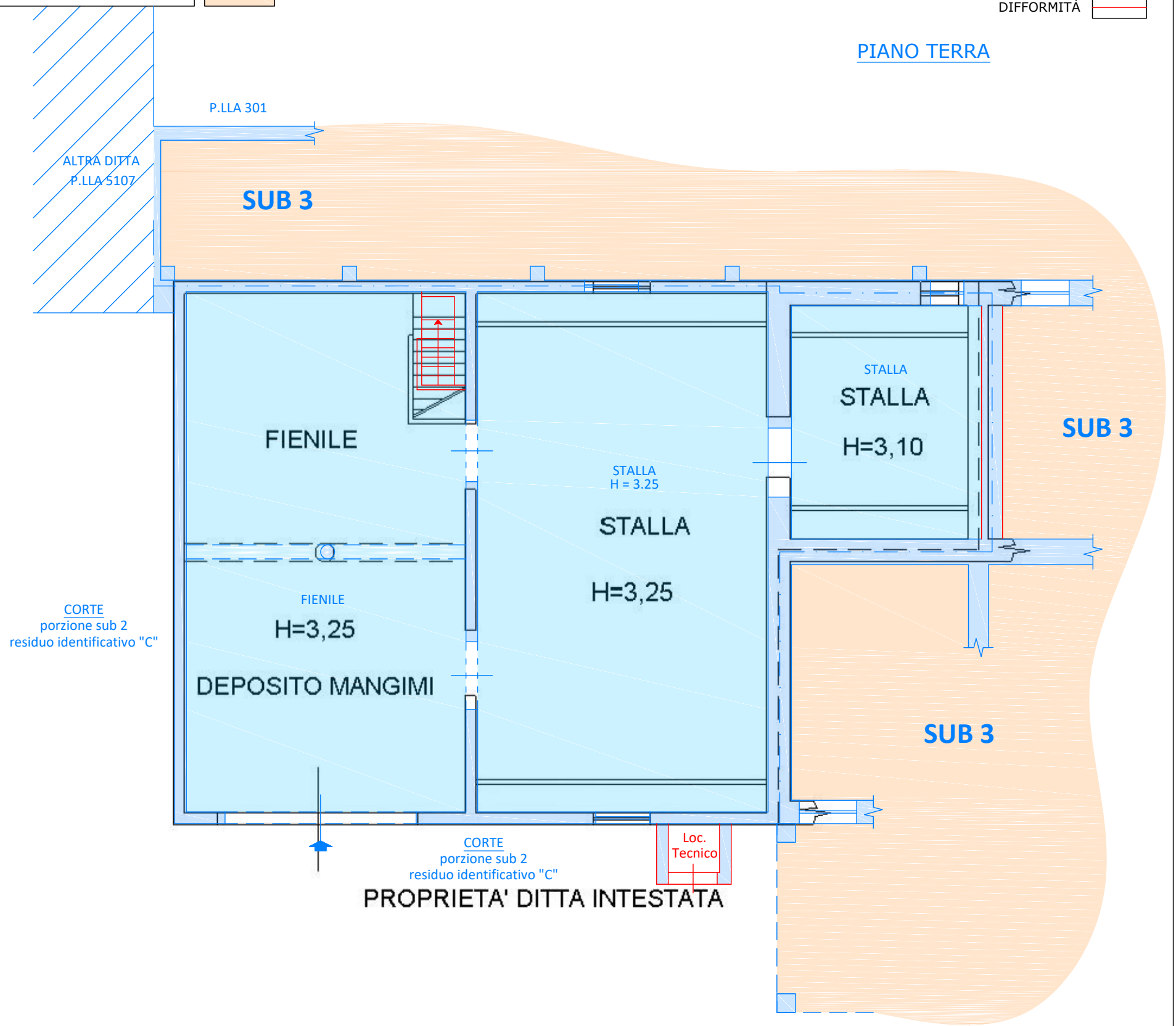

PIANO TERRA

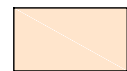

# VERIFICA CONFORMITÀ URBANISTICA

DATI CATASTALI: COMUNE DI GIOIA SANNITICA, FOGLIO 3 P.LLA 5103 SUB 2-3

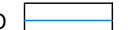
-  fabbricato - SUB 2
-  fabbricato - SUB 3

-  PLANIMETRIA DI RILIEVO
-  PLANIMETRIA TITOLO EDILIZIO
-  DIFFORMITÀ

PIANO INTERRATO

STALCIO GRAFICI C.E. N°51/99

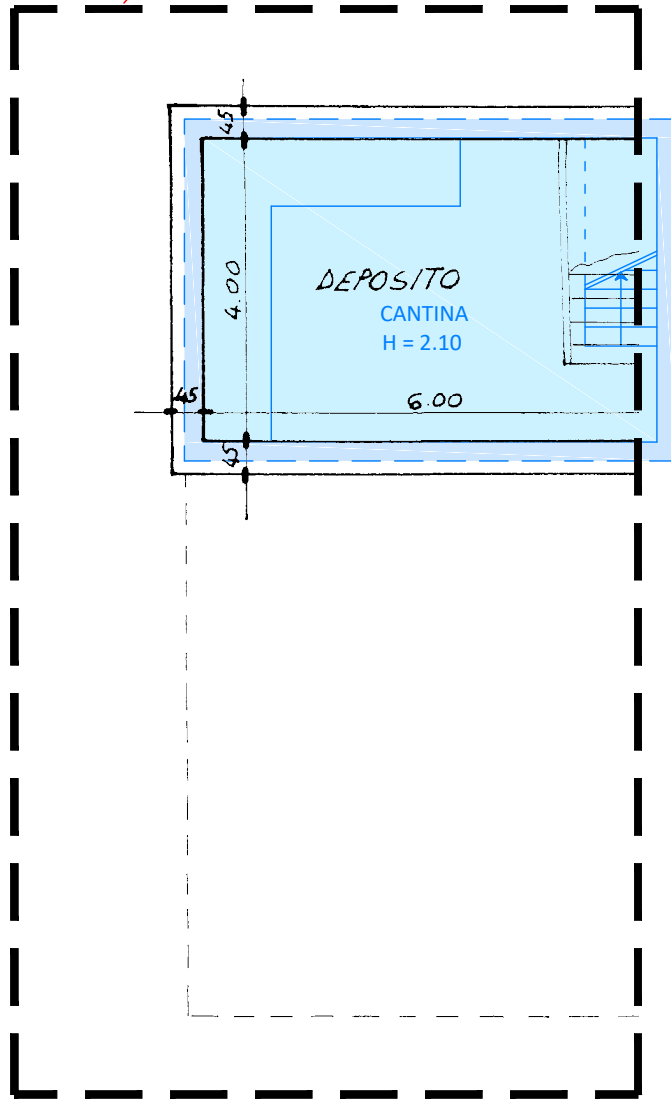

PIANO TERRA

STALCIO GRAFICI C.E. N°51/99

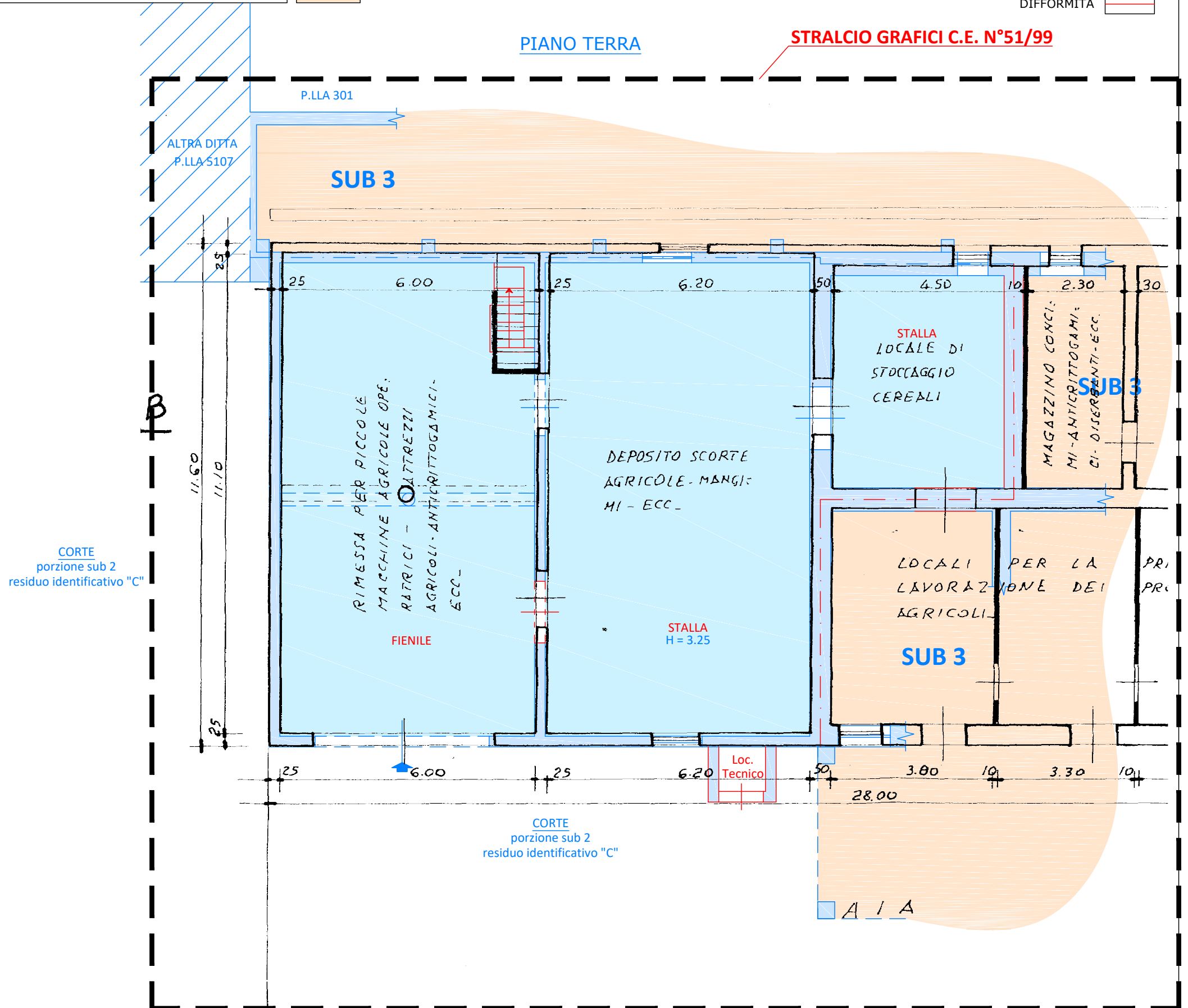

CORTE  
porzione sub 2  
residuo identificativo "C"

CORTE  
porzione sub 2  
residuo identificativo "C"





# RILIEVO DELLO STATO DEI LUOGHI

DATI CATASTALI: COMUNE DI GIOIA SANNITICA, FOGLIO 3 P.LLA 5103 SUB 2-3

 **fabbricato - SUB 2**

 **fabbricato - SUB 3**

## PIANO TERRA - livello 1

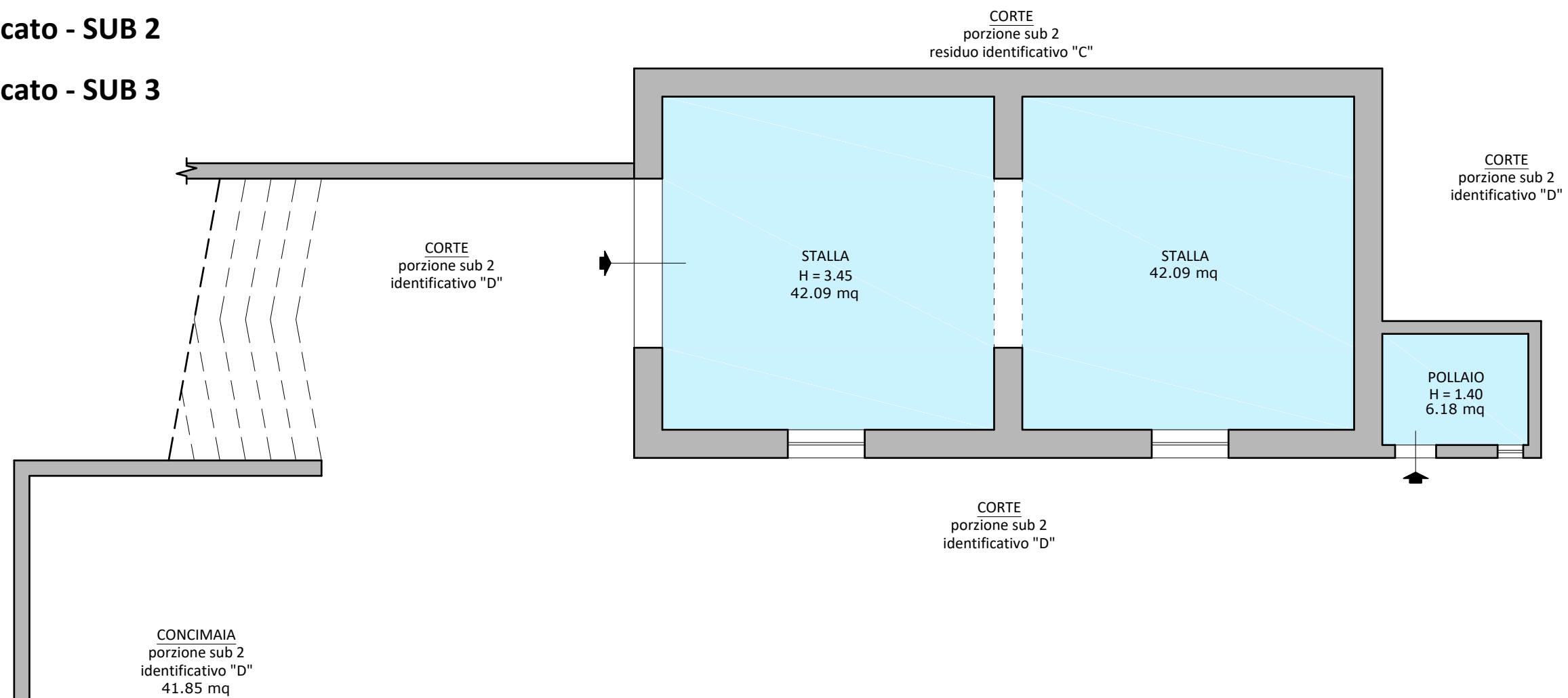

## PIANO TERRA - livello 2

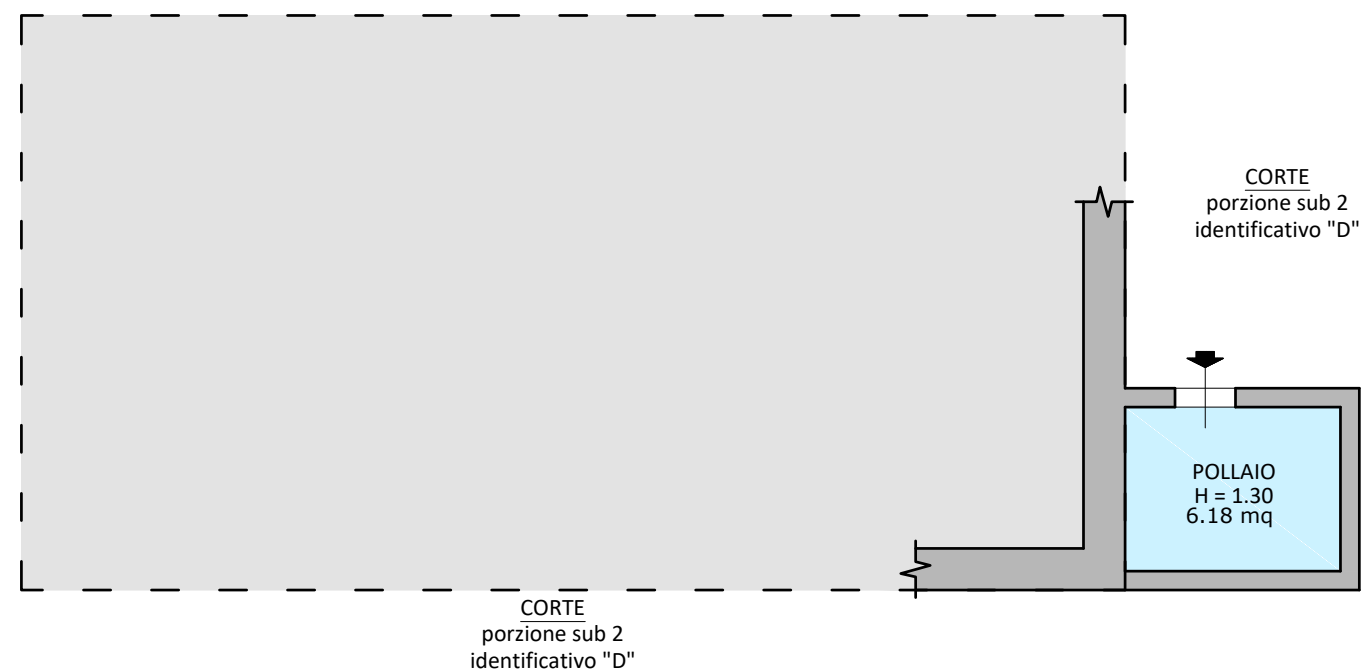

# VERIFICA CONFORMITÀ CATASTALE

DATI CATASTALI: COMUNE DI GIOIA SANNITICA, FOGLIO 3 P.LLA 5103 SUB 2-3

 fabbricato - SUB 2

 fabbricato - SUB 3

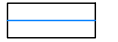
PLANIMETRIA DI RILIEVO 

PLANIMETRIA CATASTALE 

DIFFORMITÀ 

## PIANO TERRA - livello 1

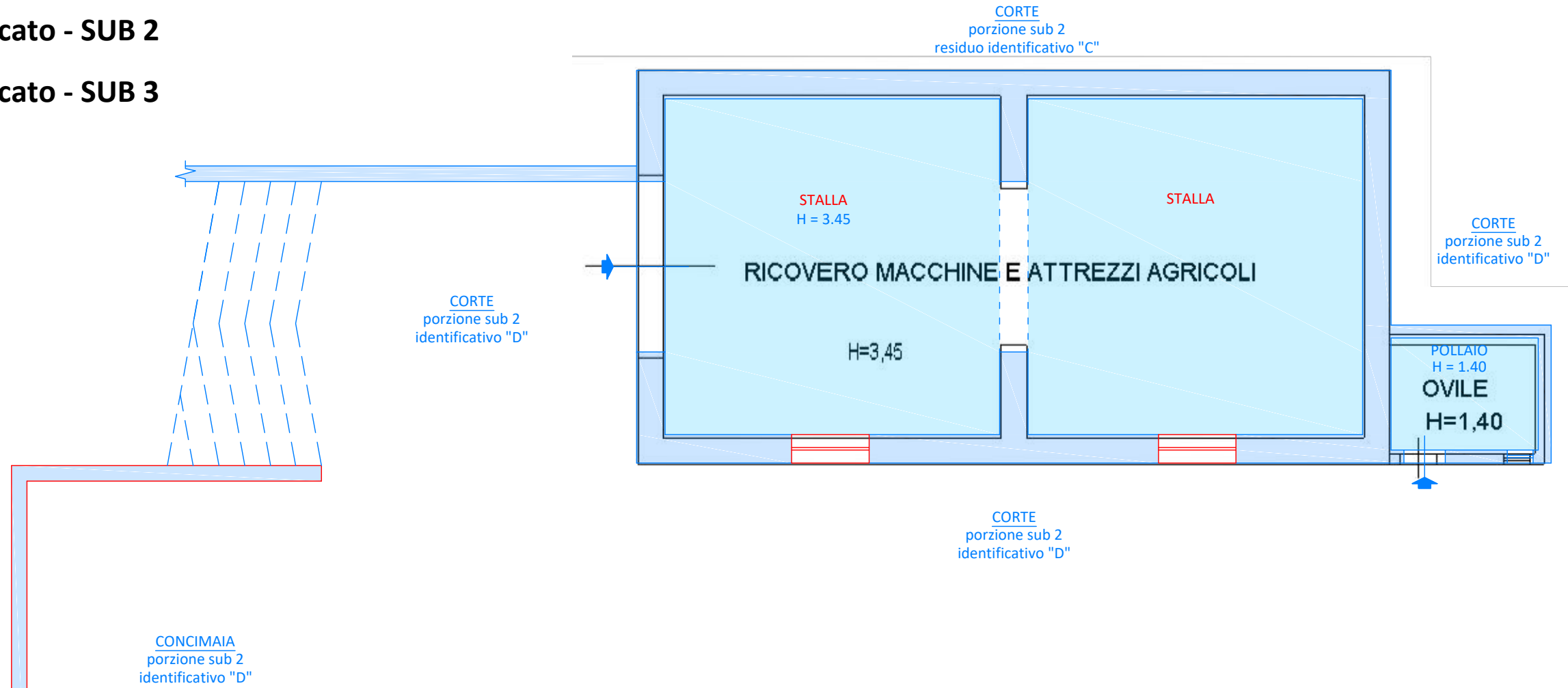

## PIANO TERRA - livello 2

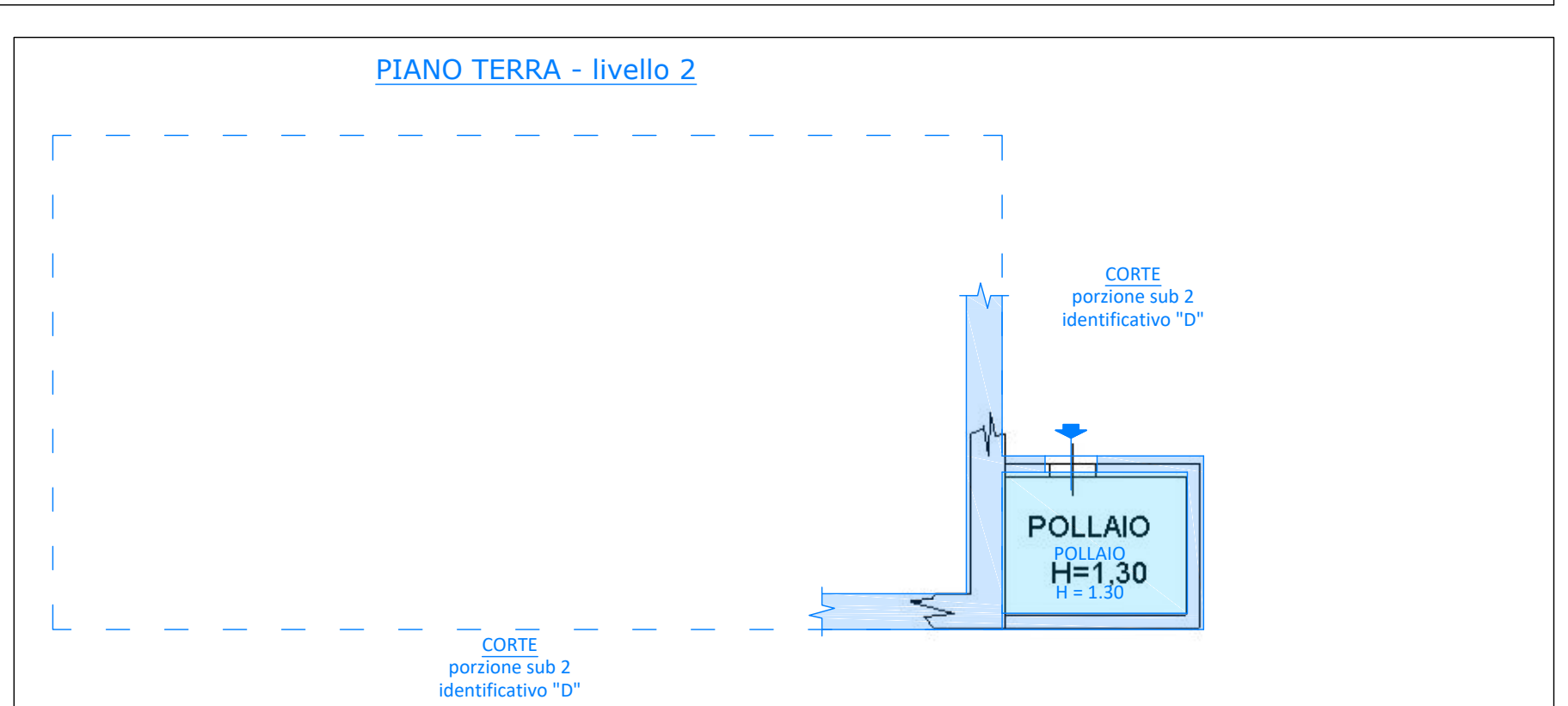

# VERIFICA CONFORMITÀ URBANISTICA

DATI CATASTALI: COMUNE DI GIOIA SANNITICA, FOGLIO 3 P.LLA 5103 SUB 2-3

PIANO TERRA - livello 1

STRALCIO GRAFICI C.E. N°01/2007

PLANIMETRIA DI RILIEVO

PLANIMETRIA TITOLO EDILIZIO

DIFFORMITÀ

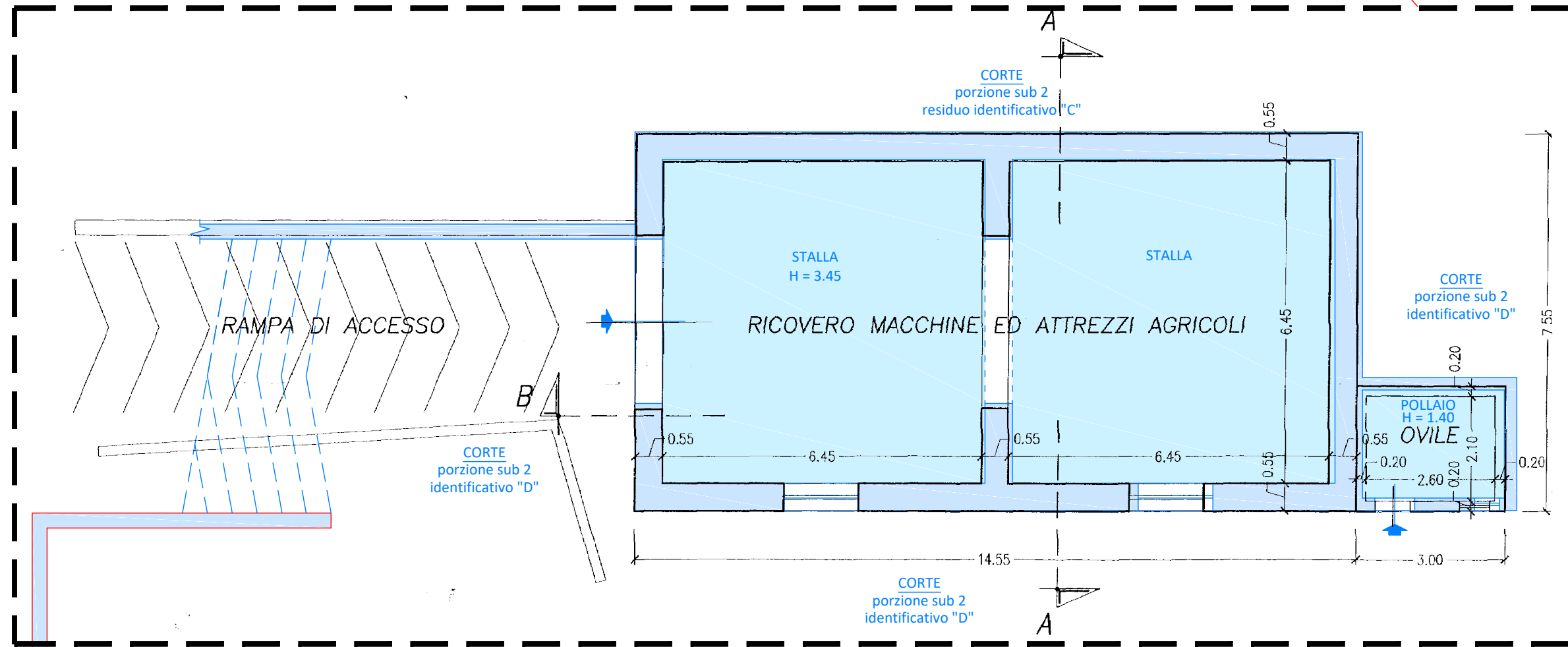

CONCIMAIA  
porzione sub 2  
identificativo "D"

PIANO TERRA - livello 2

STRALCIO GRAFICI C.E. N°01/2007

CORTE  
porzione sub 2  
identificativo "D"

POLLAIO  
POLLAIO  
H = 1.30

CORTE  
porzione sub 2  
identificativo "D"

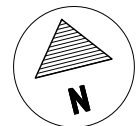

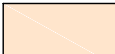
-  fabbricato - SUB 2
-  fabbricato - SUB 3

# RILIEVO DELLO STATO DEI LUOGHI

DATI CATASTALI: COMUNE DI GIOIA SANNITICA, FOGLIO 3 P.LLA 5103 SUB 2-3



foto 1



foto 2



foto 3



foto 4



## PIANO SECONDO SOTTOTETTO NON ABITABILE IN COMUNE AI SUB 2-3

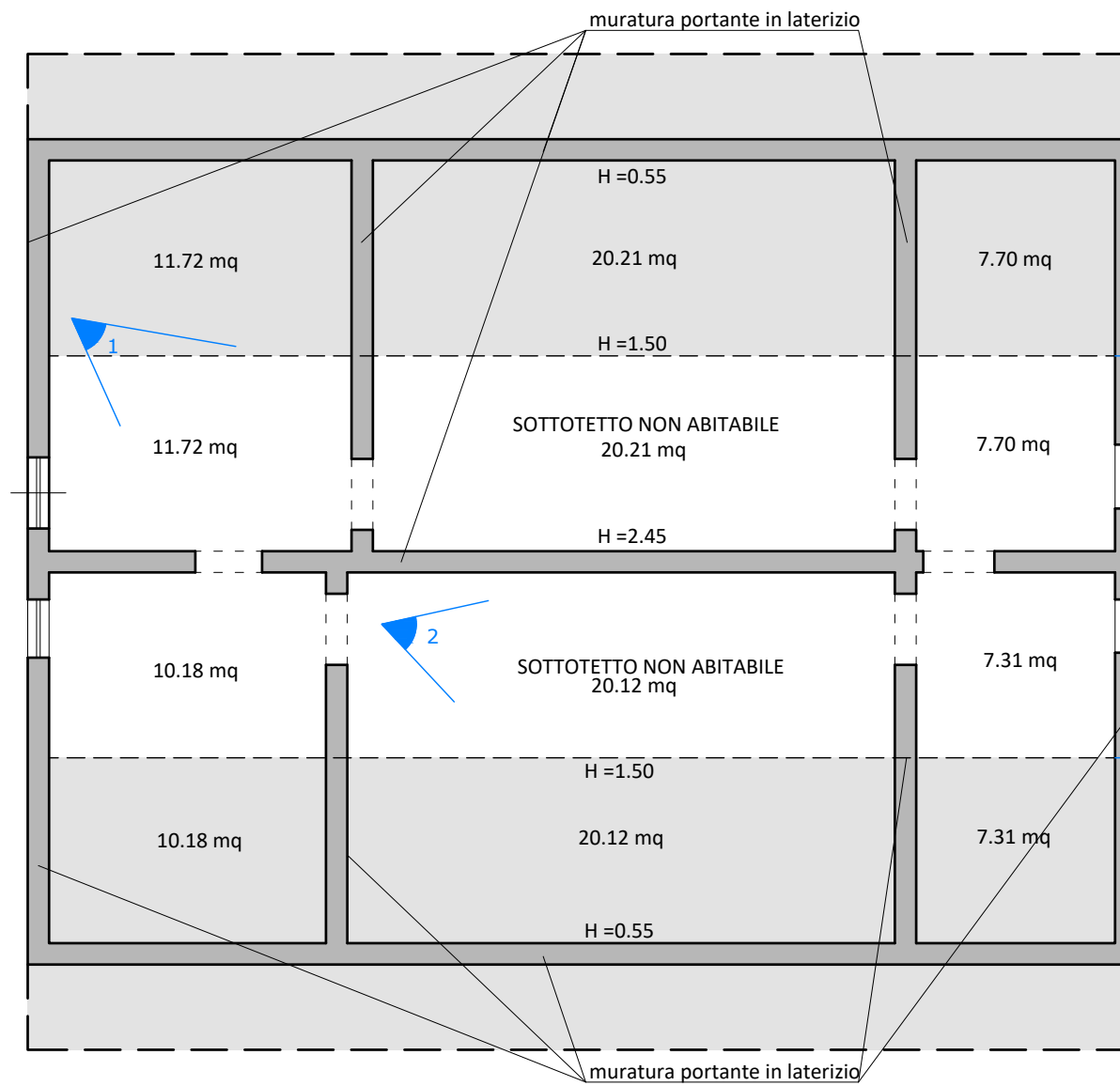

**TETTO CON ORDITURA  
IN LEGNO**

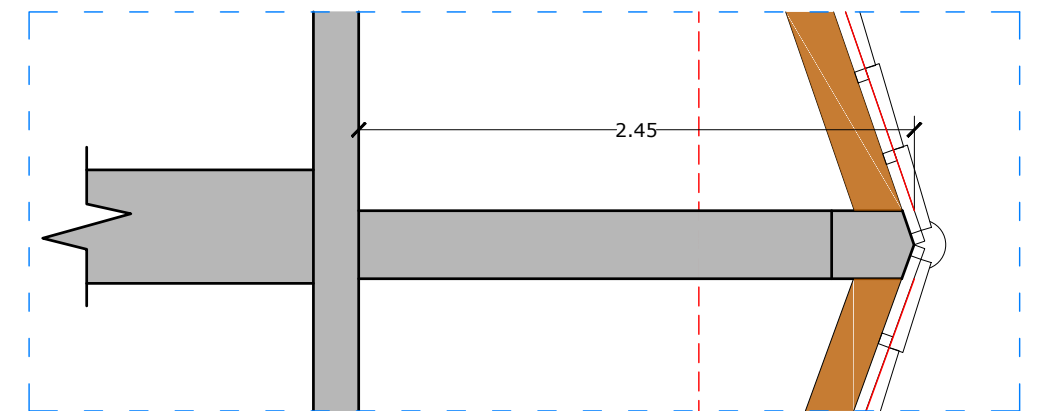
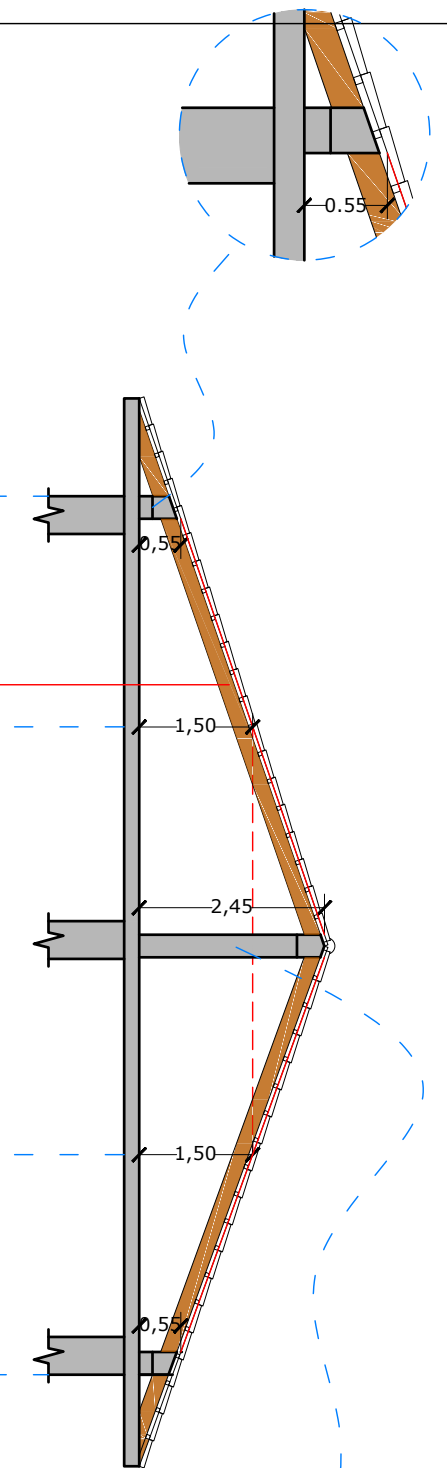

# VERIFICA CONFORMITÀ CATASTALE

DATI CATASTALI: COMUNE DI GIOIA SANNITICA, FOGLIO 3 P.LLA 5103 SUB 2-3

## SOTTOTETTO NON ABITABILE IN COMUNE AI SUB 2-3

### PIANO SECONDO

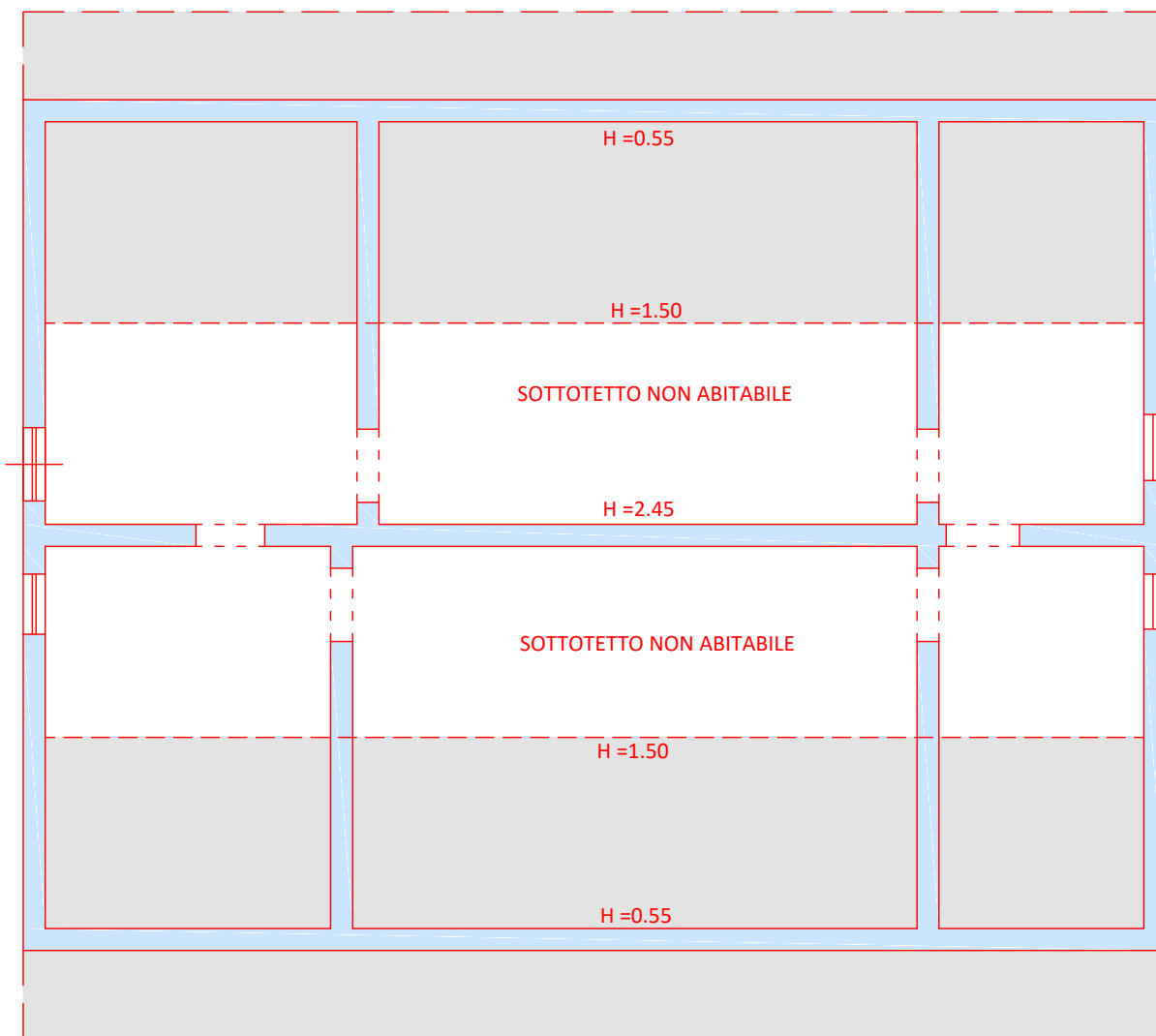

|                        |  |
|------------------------|--|
| PLANIMETRIA DI RILIEVO |  |
| PLANIMETRIA CATASTALE  |  |
| DIFFORMITÀ             |  |

**VERIFICA CONFORMITÀ URBANISTICA**

DATI CATASTALI: COMUNE DI GIOIA SANNITICA, FOGLIO 3 P.LLA 5103 SUB 2-3

**SOTTOTETTO NON ABITABILE IN COMUNE AI SUB 2-3**

**TETTO CON ORDITURA IN LEGNO**

**STRALCIO GRAFICI C.E. N°51/99**



foto 1



foto 2



foto 3



foto 4

**TETTO CON ORDITURA IN LEGNO**

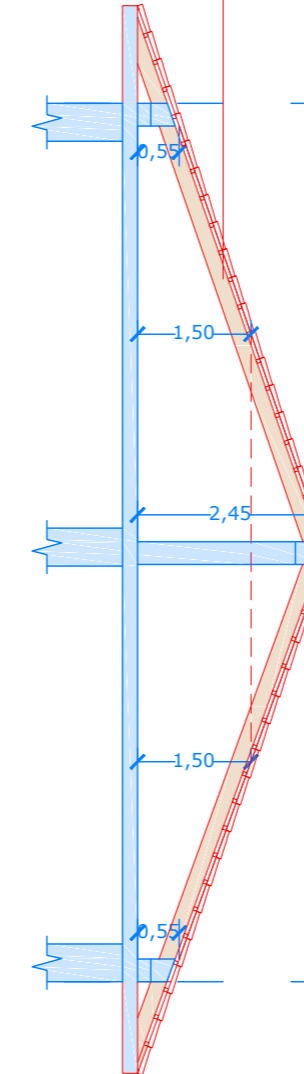
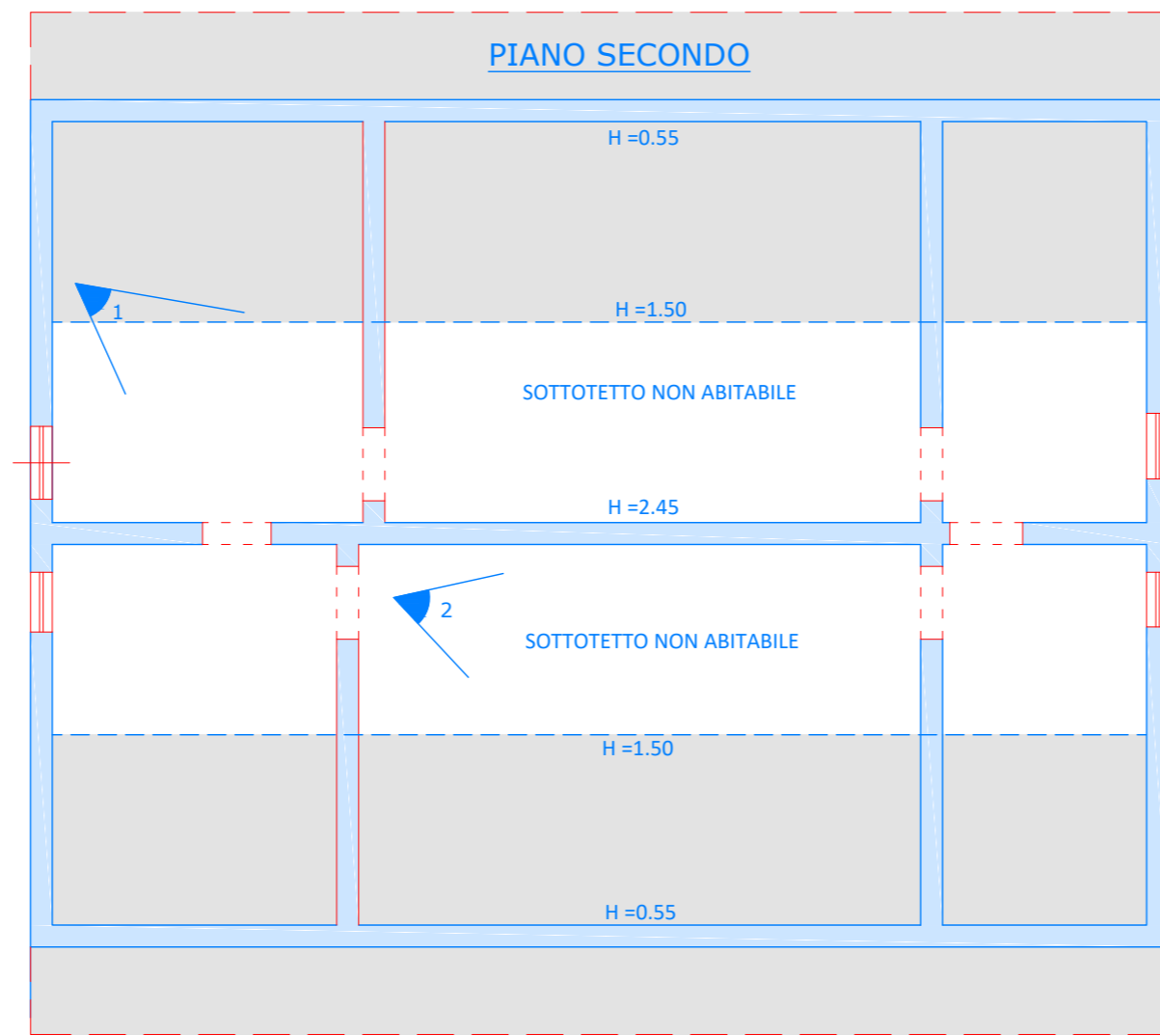

**STRALCIO GRAFICI C.E. N°51/99**

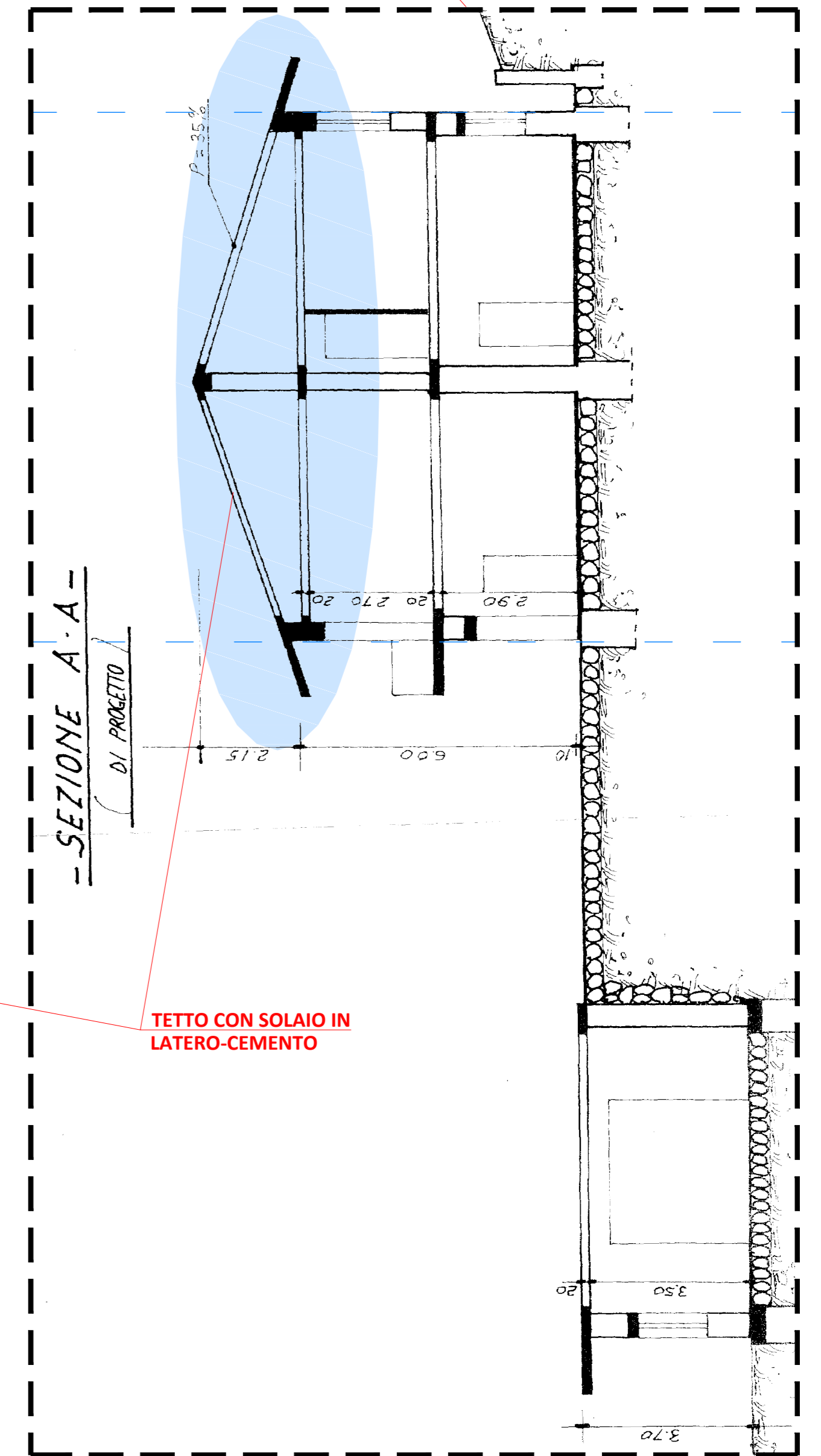
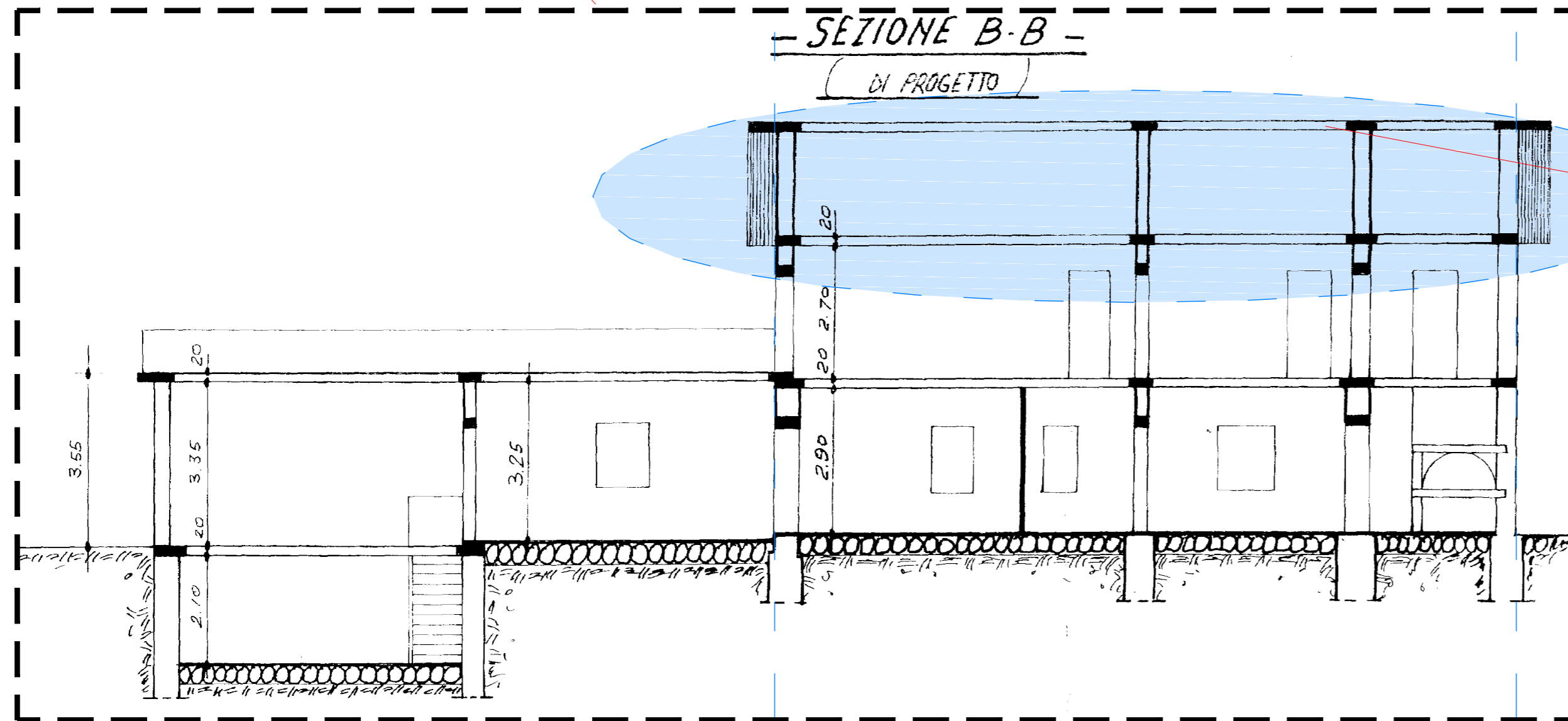

**TETTO CON SOLAIO IN LATERO-CEMENTO**

DIM.  
700X400

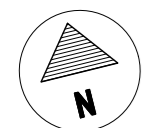

# RILIEVO DELLO STATO DEI LUOGHI

DATI CATASTALI: COMUNE DI GIOIA SANNITICA, FOGLIO 3 P.LLA 301

MANUFATTO EDIFICATO SULLA P.LLA 301 FOGLIO 3

## PIANO TERRA

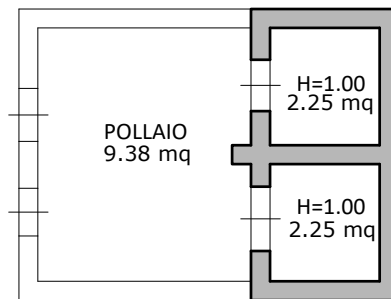

# VERIFICA CONFORMITÀ CATASTALE

DATI CATASTALI: COMUNE DI GIOIA SANNITICA, FOGLIO 3 P.LLA 301

MANUFATTO EDIFICATO SULLA P.LLA 301 FOGLIO 3

## PIANO TERRA

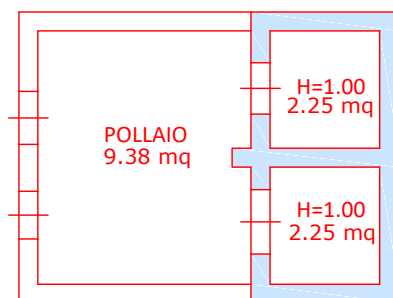

PIANIMETRIA DI RILIEVO 

PIANIMETRIA CATASTALE 

DIFFORMITÀ 



# VERIFICA CONFORMITÀ URBANISTICA

DATI CATASTALI: COMUNE DI GIOIA SANNITICA, FOGLIO 3 P.LLA 301

MANUFATTO EDIFICATO SULLA P.LLA 301 FOGLIO 3

## PIANO TERRA

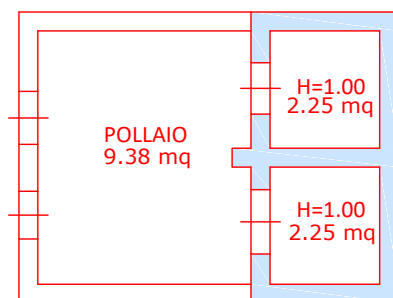

PLANIMETRIA DI RILIEVO 

PLANIMETRIA TITOLO EDILIZIO 

DIFFORMITÀ 