

PIANO SECONDO



Foto 21 – Foto 22 – Camera Matrimoniale



Foto 23 – Foto 24 – Camera Matrimoniale



Foto 25 – Foto 26 – Foto 27 – Bagno 2



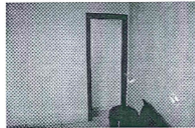

Foto 11 – Foto 12 – Bagno 1



Foto 13 – Scale tra P. Terra e P. Primo

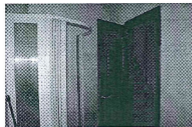

Foto 14 – Sbarco scale



PIANO PRIMO



Foto 15 – Foto 16 – Living



Foto 17 – Living e angolo cottura



Foto 18 – Particolare angolo cottura



Foto 19 – Scala tra P. Primo e P. Secondo



Foto 20 – Sbarco scala



PIANO TERRA



Foto 05 - Uscio con gradino



Foto 06 - Ingresso con scala



Foto 07 - Ingresso con accesso al bagno 1



Foto 08 - Vista ripostiglio



Foto 09 - Foto 10 - Stanza Plurifuso





Foto 01 - L'ala immobiliare cielo-terra Via Crognaleto, 86

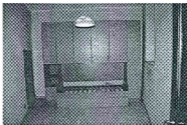

Foto 02 - Vista altre tre finestre Via Crognaleto



Foto 03 - Portone di ingresso



Foto 04 - Vista finestre P.T. e P.P.





Foto 01 - L'ala immobiliare cielo-terra Via Crognaleto, 86



Foto 02 - Vista altre tre finestre Via Crognaleto



Foto 03 - Portone di ingresso



Foto 04 - Vista finestre P.T. e P.P.



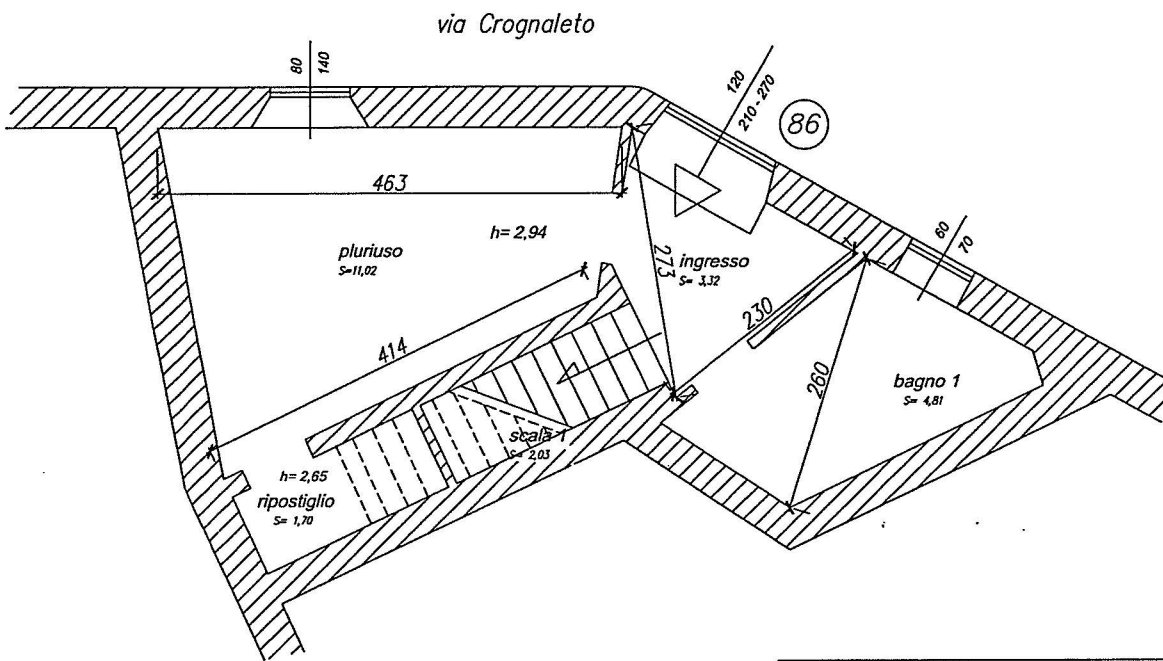

Piano Terra

in Catasto: foglio MU, p.lla 368, sub 2

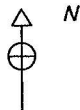

TRIBUNALE DI VELLETRI <small>sezione ESECUZIONI IMMOBILIARI - N.R.G.E.</small>	
scala 1:50	[REDACTED]
data Dic. 2023	Rilievo Appartamento ARTENA - Via Crognaleto, 86
TAV. 01/03	Allegato alla RELAZIONE del C. T. U. <small>ing. GIORGIO TAGLIAFERRI - Velletri - 339842188 - g.tagliaferri@pec.ording.roma.it - ing.giorgiotagliaferri@gmail.com</small>

Firmato Da: TAGLIAFERRI GIORGIO Emesso Da: ARUBAPECS.P.A. NG CA 3 Serial#: 500e64cb420ae2fb1bacc947a85371



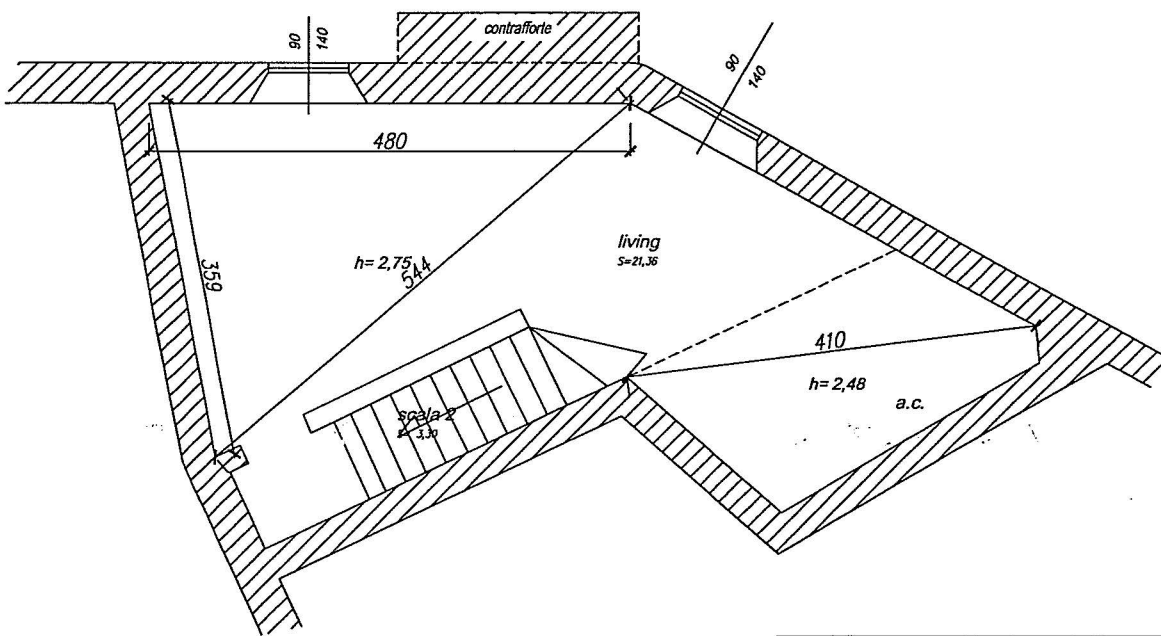

Piano Primo

in Catasto: foglio MU, p.la 368, sub 2

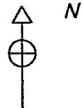

TRIBUNALE DI VELLETRI

sezione ESECUZIONI IMMOBILIARI - N.R.G.E. [REDACTED]

scala 1:50	[REDACTED]
data Dic. 2023	Rilievo Appartamento ARTENA - Via Crognaleto, 86
TAV. 02/03	Allegato alla RELAZIONE del C. T. U. ing. GIORGIO TAGLIAFERRI - Velletri - 3398442188 g.tagliaferri@pec.ording.roma.it - ing.giorgio.tagliaferri@gmail.com



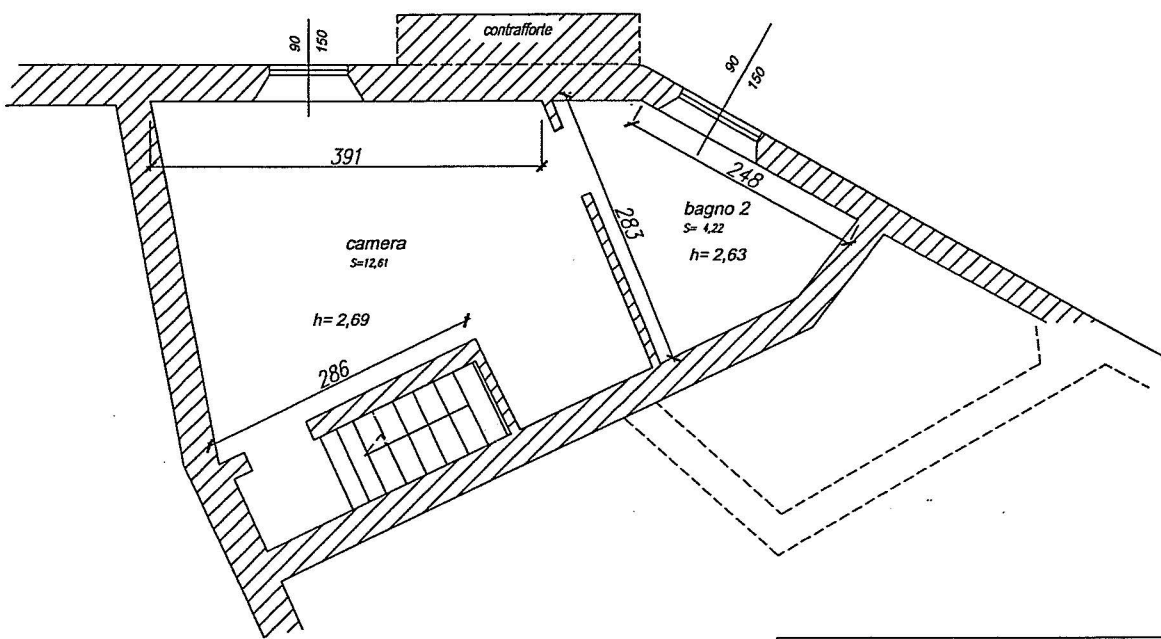

Piano Secondo

in Catasto: foglio MU, p.lla 368, sub 2

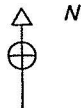

TRIBUNALE DI VELLETRI <small>sezione ESECUZIONI IMMOBILIARI - N.R.G.E.</small>	
scala 1:50	[REDACTED]
data Dic. 2023	Rilievo Appartamento ARTENA - Via Crognaleto, 86
TAV. 03/03	Allegato alla RELAZIONE del C. T. U. <small>ing. GIORGIO TAGLIAFERRI - Velletri - 3398442188 .g.tagliaferri@pec.ording.roma.it - ing.giorgiotagliaferri@gmail.com</small>

Firmato Da: TAGLIAFERRI GIORGIO Emesso Da: ARUBAPEG S.P.A. NG CA 3-Seriff: 500e54cb#420ae2fb1bace547a8597f

