

Scala U Interno 26 Piano S1

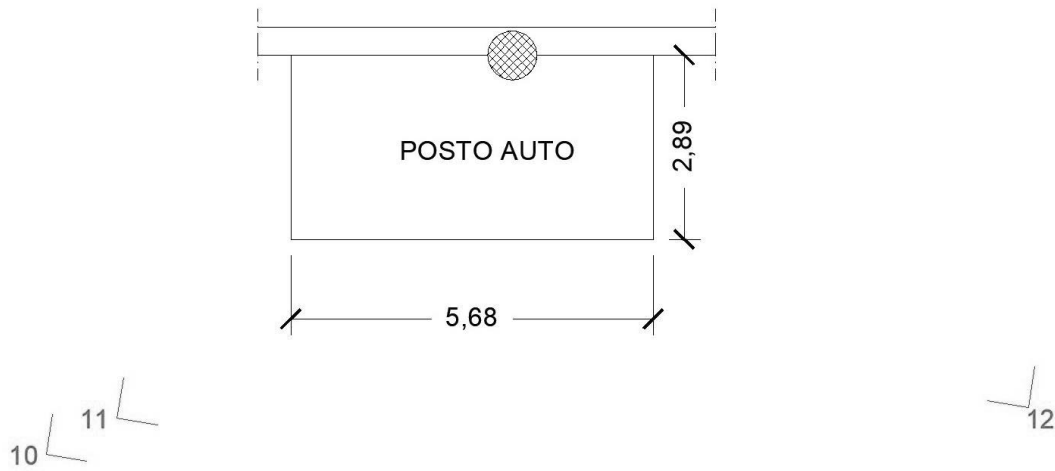

Grafico 3 LOTTO 2: posto auto n.26

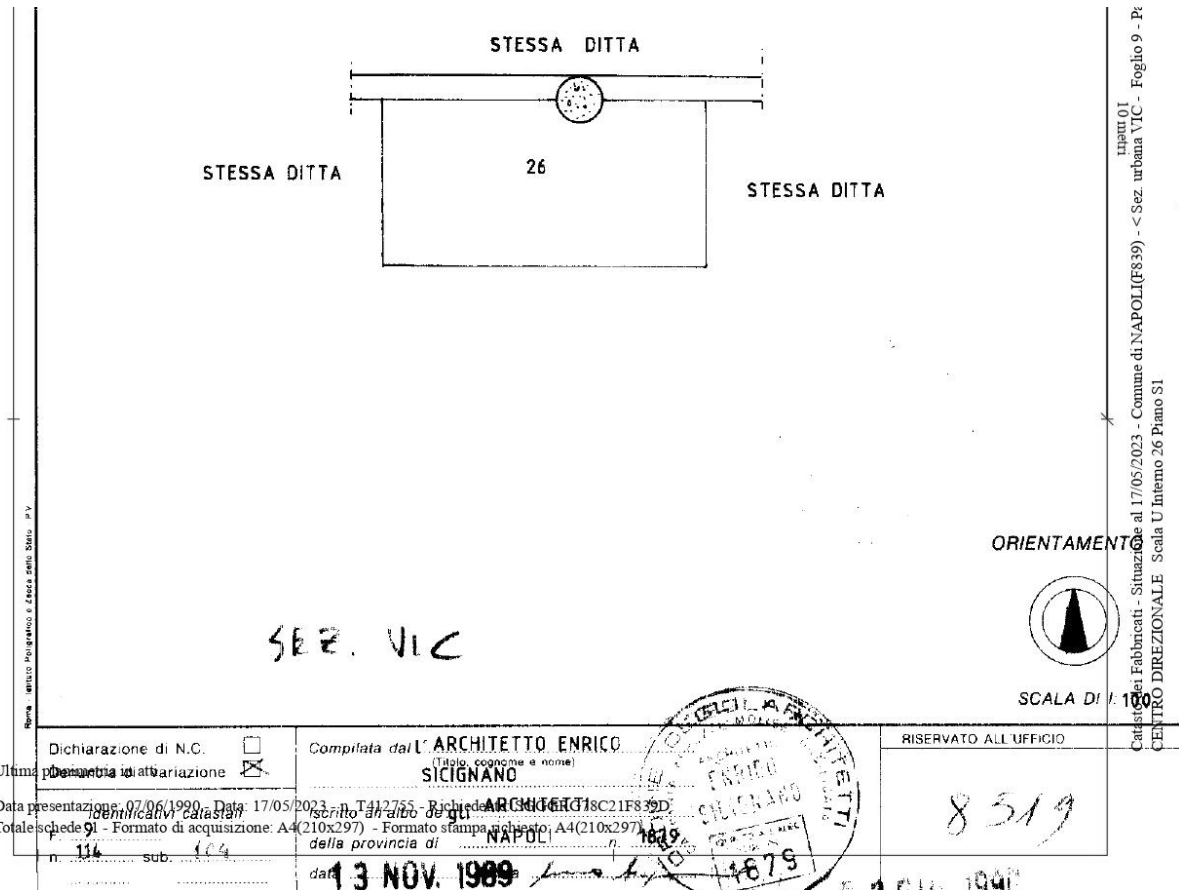

Figura 4: LOTTO 2_ sc. U, int. 26, piano S1_ planimetria catastale dell'immobile avente data presentazione: 07/06/1990.