

Individuazione dei beni pignorati – Lotto 2

Stralcio Google Earth Pro



Stralcio GeoPortale – Regione Lombardia



● edificio A ● edificio B ● edificio C

Stralcio estratto mappa Foglio 6 mapp. 698

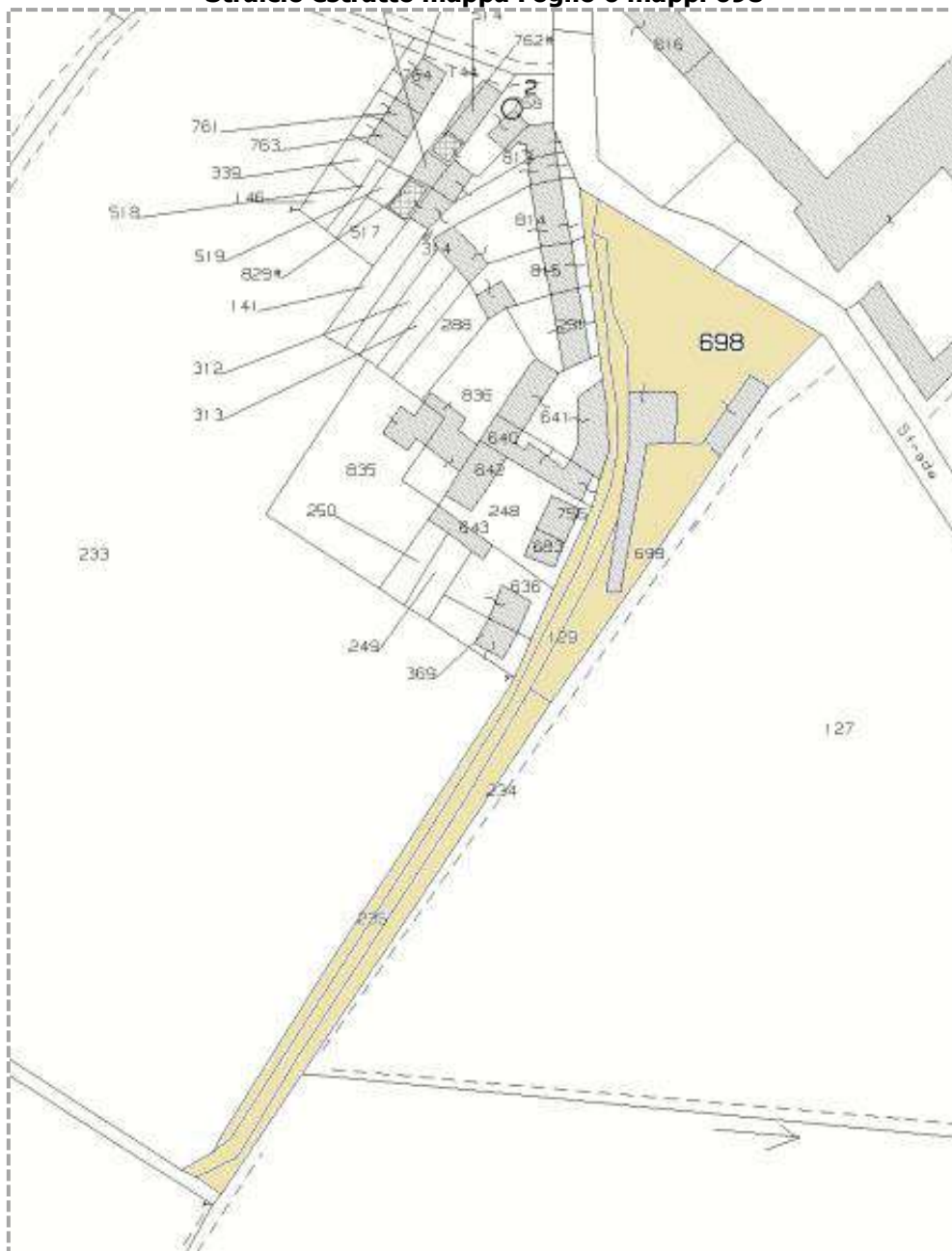

Elenco beni secondo le risultanze catastali attuali

Edificio	n.	Fg	CF/CT	Mappale	sub	categoria / qualità
A	1	6	CF	698	2	A/4 - Abitazione di tipo popolare
	2	6	CF	698	3	A/4 - Abitazione di tipo popolare
B	3	6	CF	698	4	C/2 - Abitazione di tipo popolare
				699		
C	4	6	CF	698	5	A/4 - Abitazione di tipo popolare
Terreni	5	6	CT	129	-	Bosco misto
	6	6	CT	234	-	Bosco misto
	7	6	CT	235	-	Bosco misto

Stralcio elaborato planimetrico

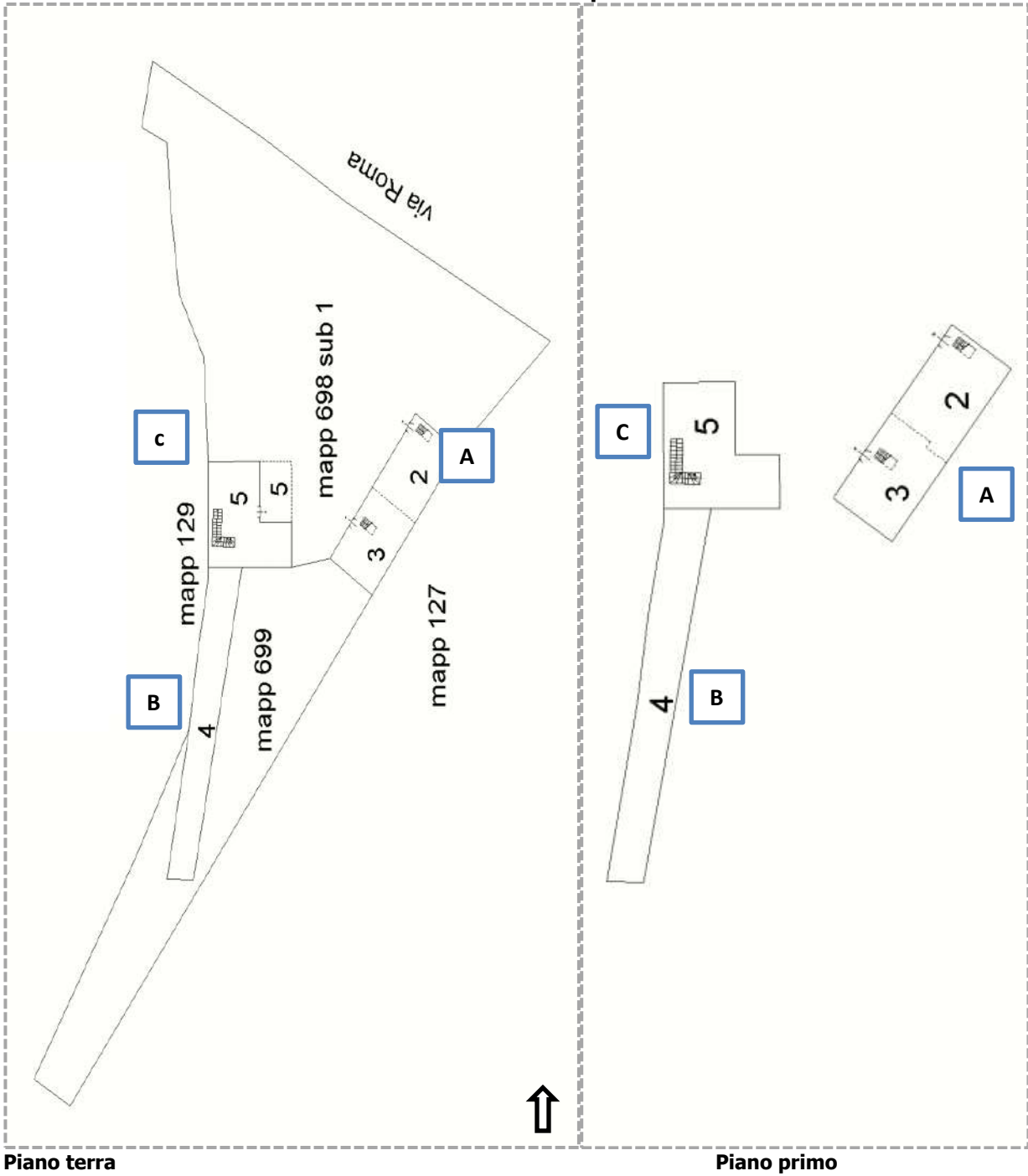

Piano terra

Piano primo

A

Fg 6 mapp. 698 sub 2

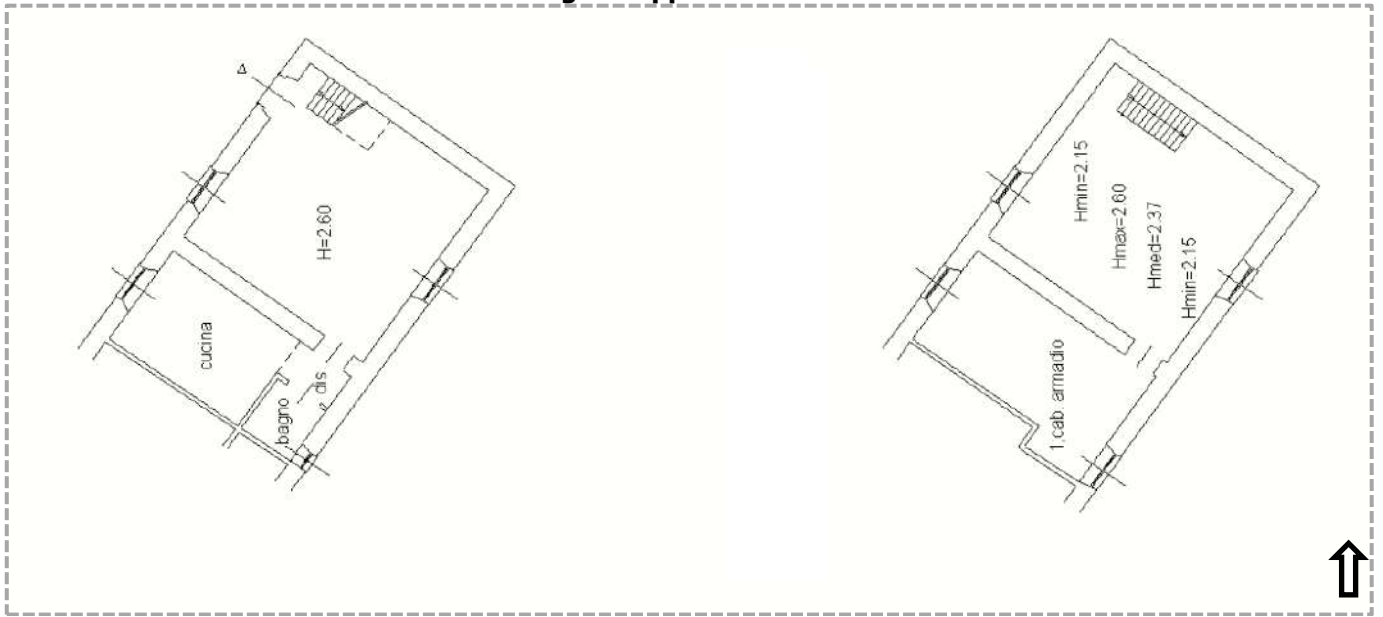

Piano terra

Piano primo

Fg 6 mapp. 698 sub 3

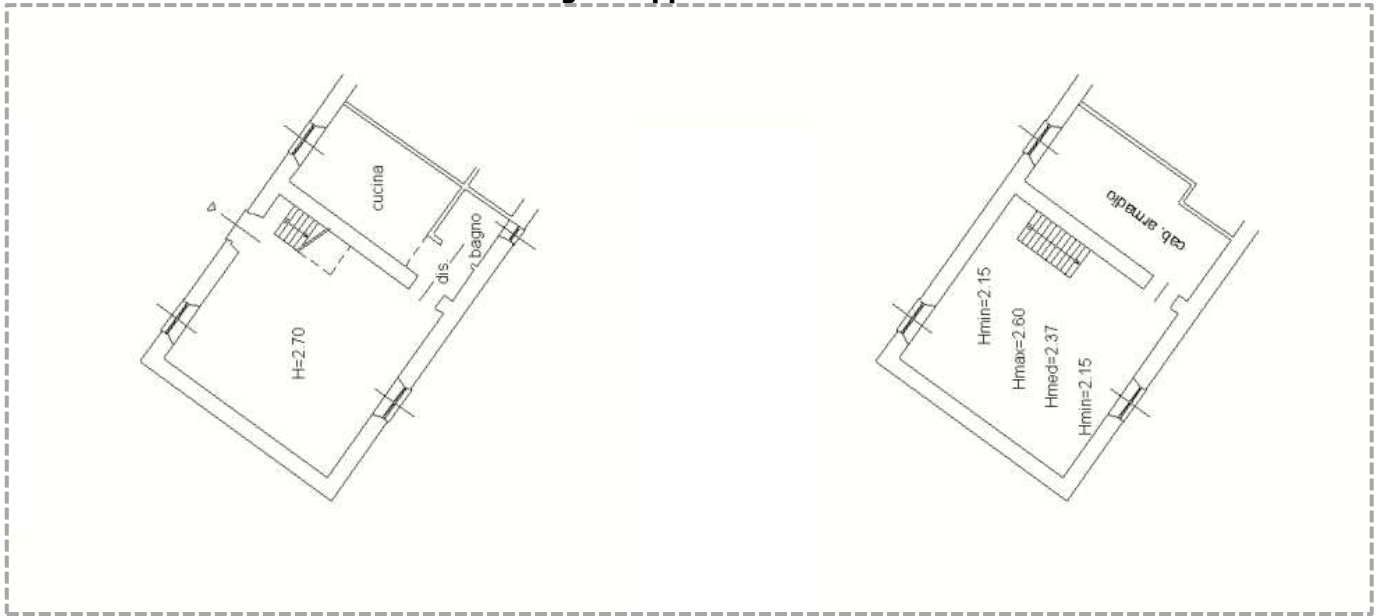

Piano terra

Piano primo

Fg 6 mapp. 698 sub 4

B

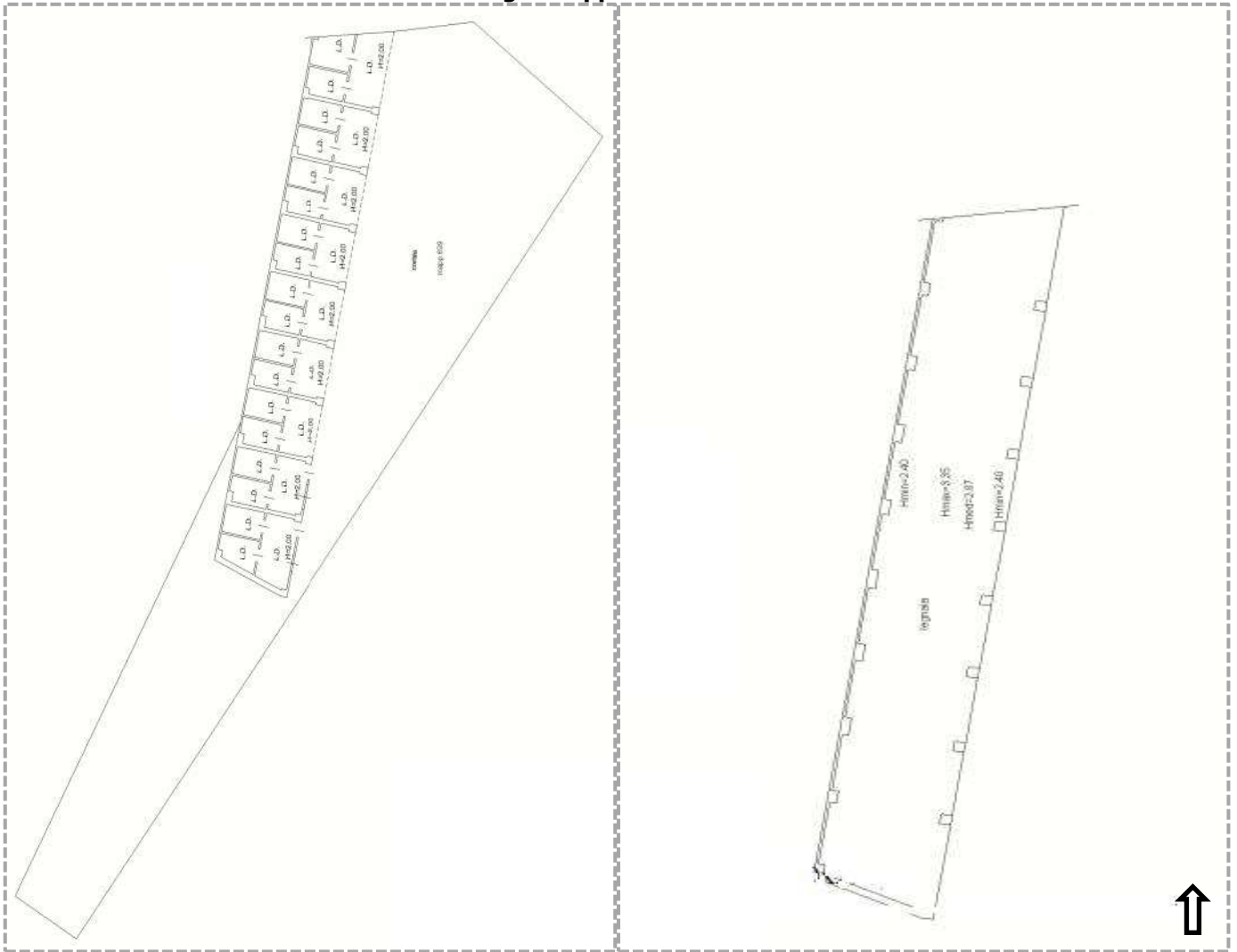

Piano terra

Piano primo

Fg 6 mapp. 698 sub 5

C

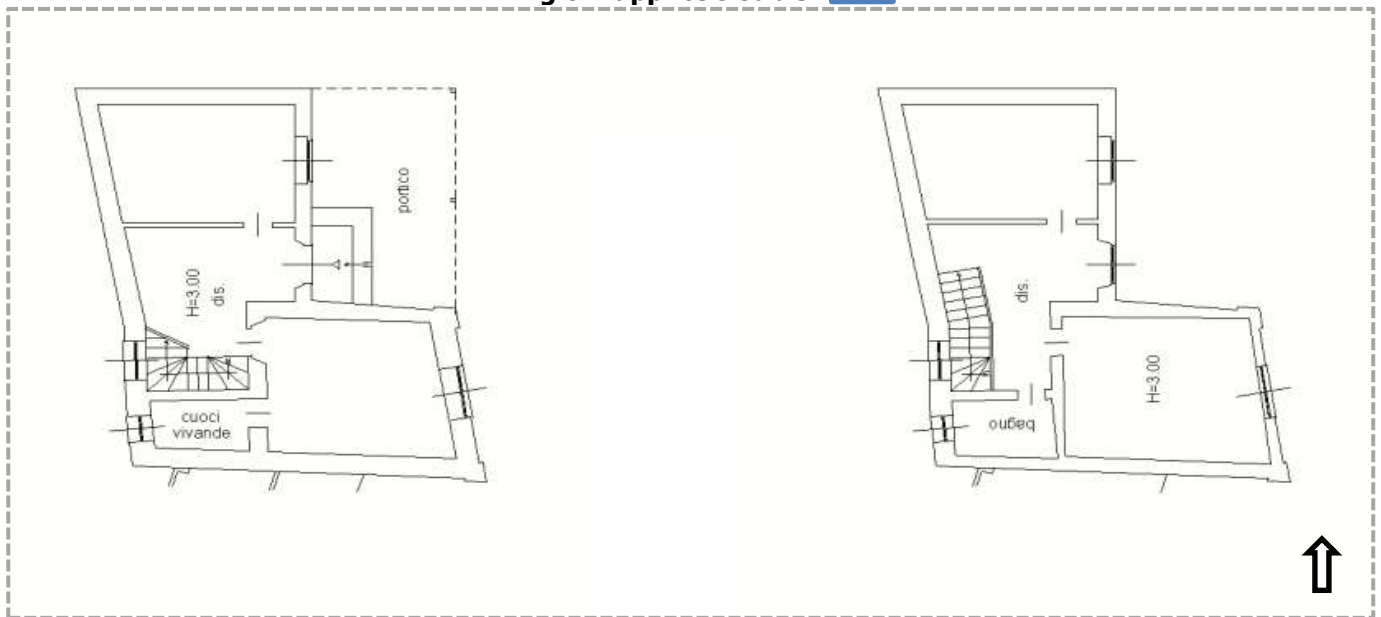

Piano terra

Piano primo



f.1 vista fabbricati dalla via Roma



f.2 vista sedime e alberi su via Roma



f.3 vista recinzione su via Roma



f.4 vista edificio A dalla via Roma



f.5 vista testa edificio B dalla stradina



f.6 vista stradina con recinzione ovest



f.7 vista edificio C dalla stradina



f.8 vista edificio C dalla stradina



f.9 vista edificio B dalla stradina



f.10 vista dissesto angolo muratura edificio C su stradina



f.12 vista edificio A dal cortile



f.13 vista testa edificio A (crollo spigolo est)



f.14 vista edificio B in stato di rudere



f.15 idem



f. 16 vista edificio C dal cortile



f.17 vista interno edificio A



f. 18 idem



f.19 idem



f.20 idem



f.21 idem



f.22 vista breccia aperta spigolo nord



f.23 vista sotto tettoia edificio C



f.24 vista vano scala edificio C

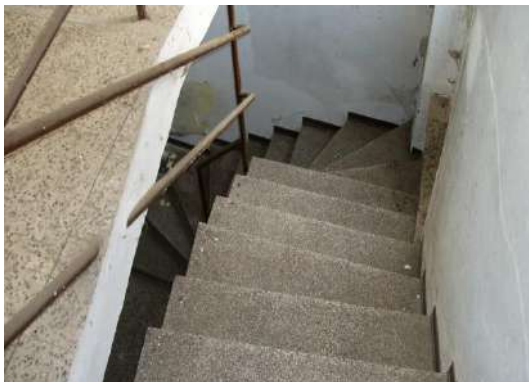

f.25 vista scala dal p. primo



f.26 vista locale



f. 27 vista disimpegno



f. 28 vista locale



f.29 vista ingresso bagno



f.30 vista manto eternit tettoia



f.31 vista bagno



f. 32 numerazione civica edificio C