

STUDIO TECNICO BARACCHI Geom. MASSIMO
 NOVELLARA Strada Borgazzo 4 - P.I. 00649770354 - C.F. BRCMSM33S17 F360H
 Tel-fax: 0522 661950 cell: 340 2330175 e-mail: stefaniabaracchi@libero.it

COMMITTENTE: **AHMED ISHTIAQ**

OGGETTO: **S.C.I.A. ripristino abusivo**

IL TECNICO: **1**

TAVOLA: **Piante - Prospetti**
 Stato Legittimato - Stato di Fatto - Stato Ripristinato
 Stato G/R

SCALA: **1:100**

DATA: **Maggio 2023**

Sede cantiere: **Via Fratelli Bandiera n°2, 42017 Novellara (RE)**

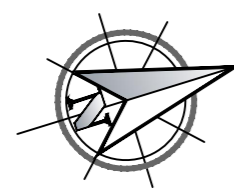

Stato Legittimato

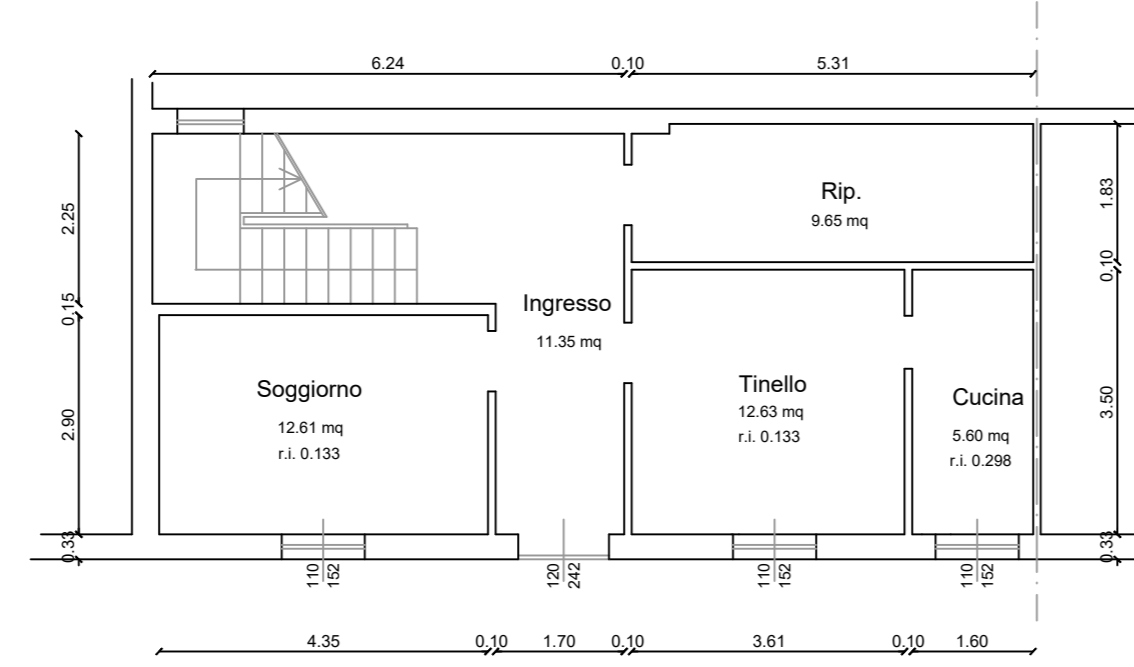

Piano Terra

Stato di Fatto

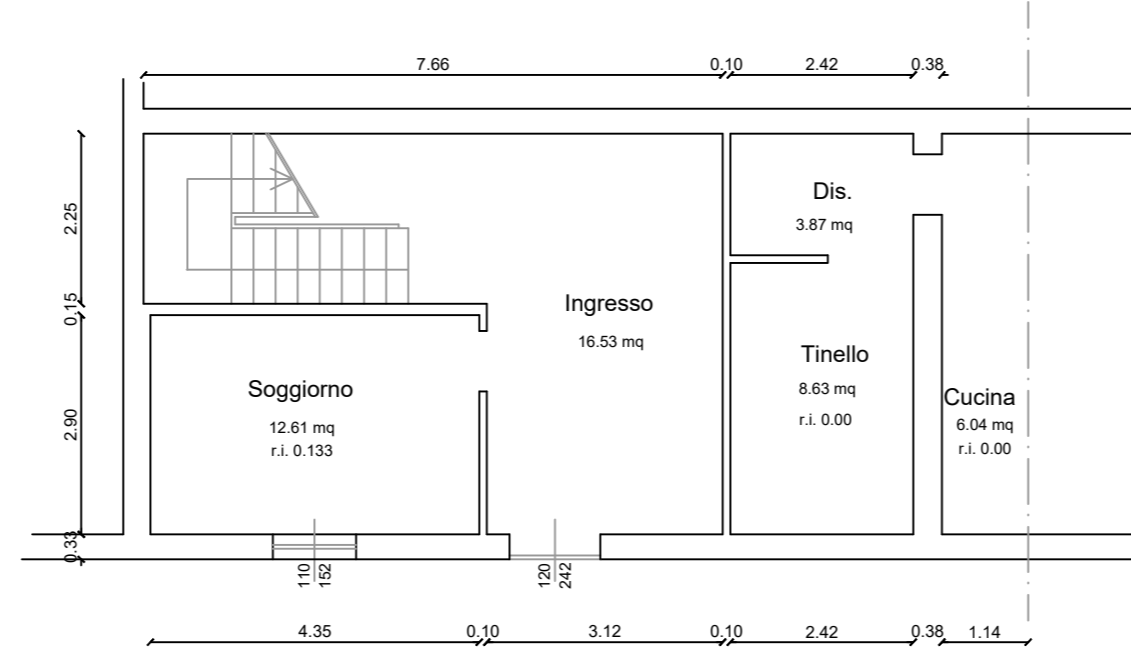

Piano Terra
h = 2.80 m

Stato G/R tra Stato Legittimato e Stato Fatto

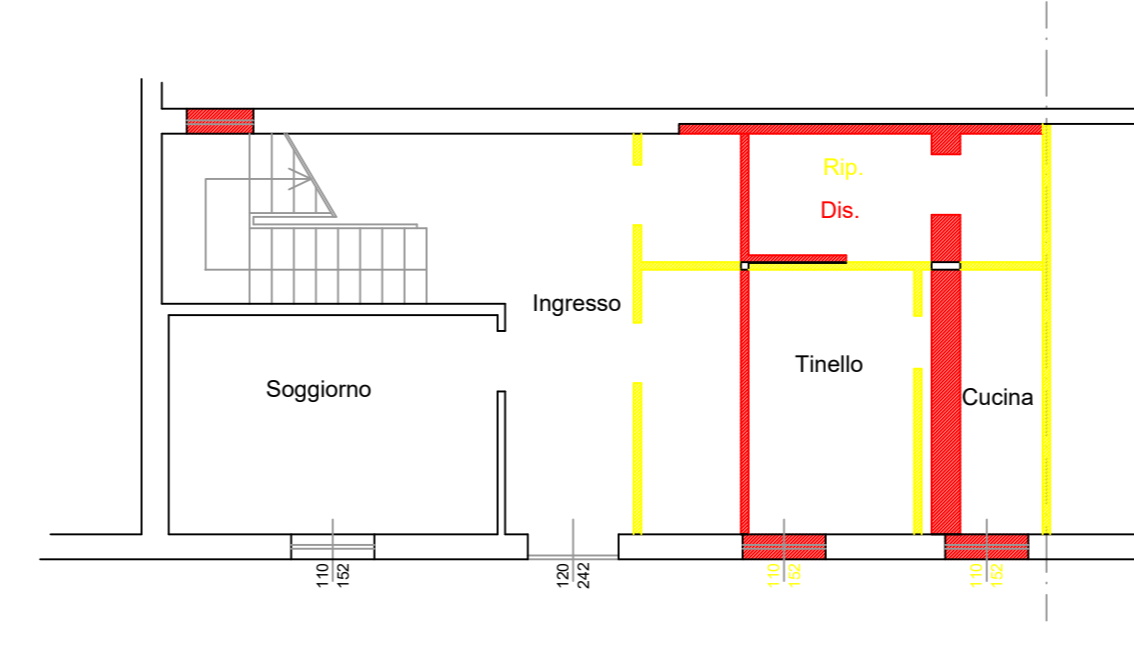

Piano Terra
h = 2.80 m

Stato Ripristinato

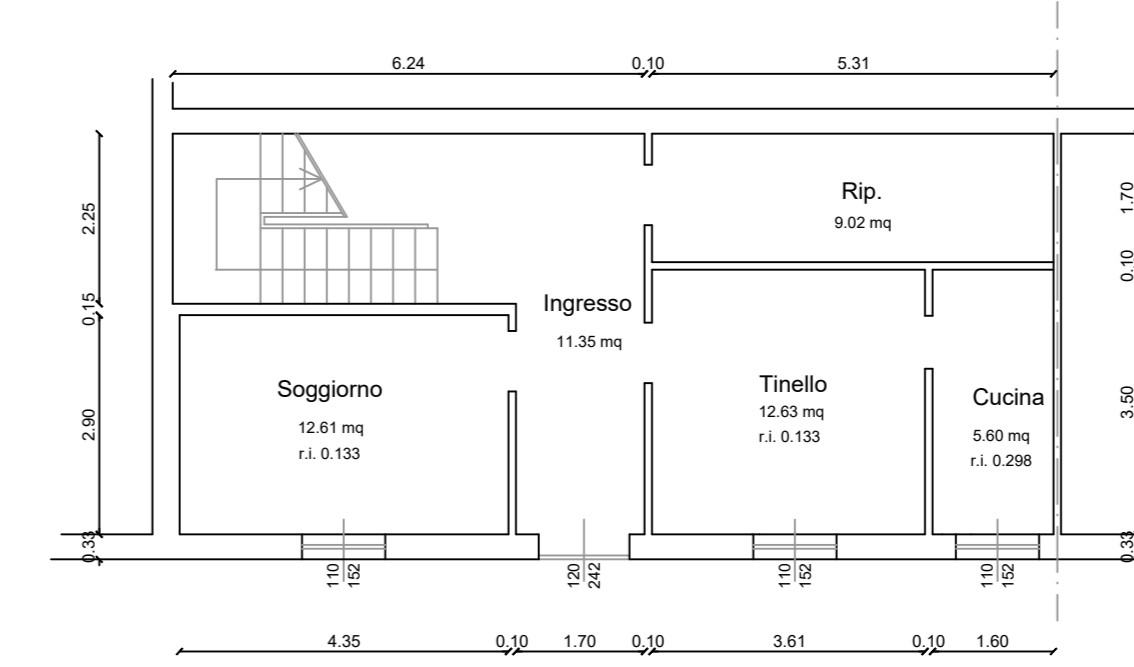

Piano Terra
h = 2.80 m

Stato G/R tra Stato di Fatto e Stato Ripristinato

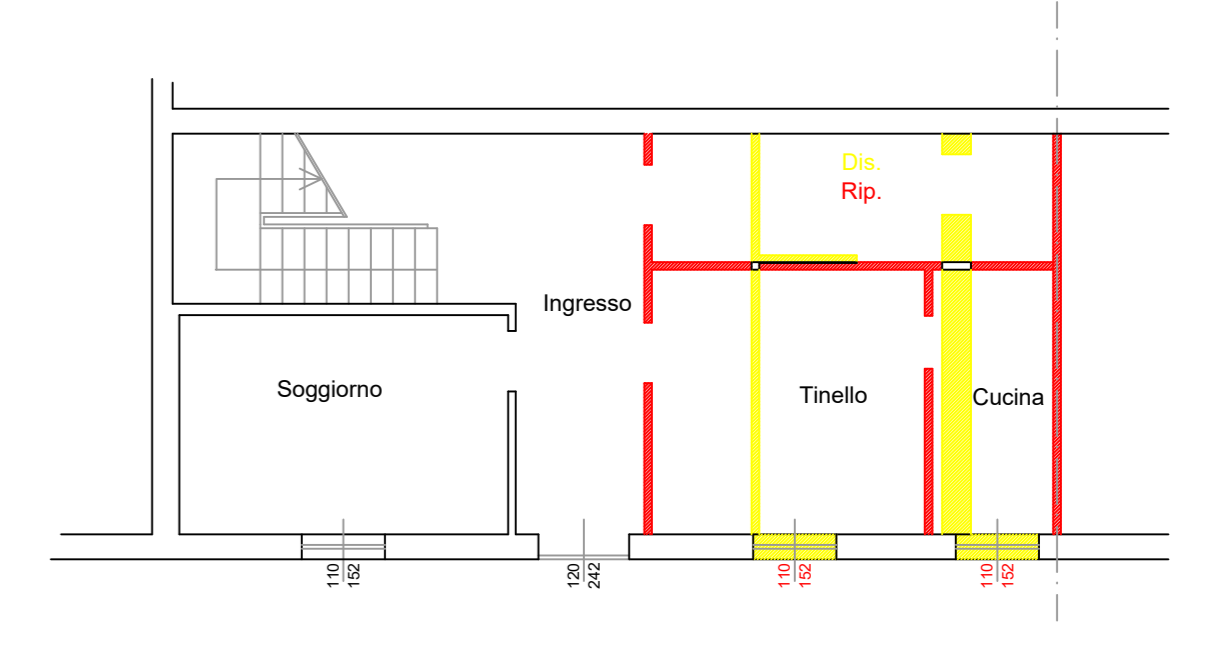

Piano Terra
h = 2.80 m

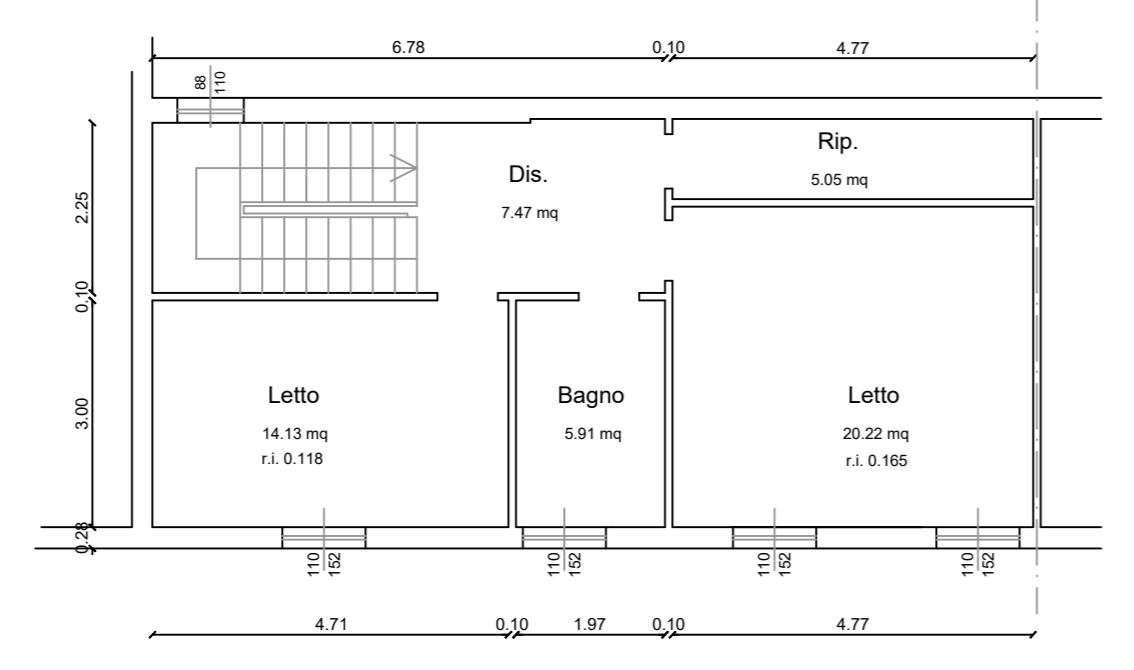

Piano Primo

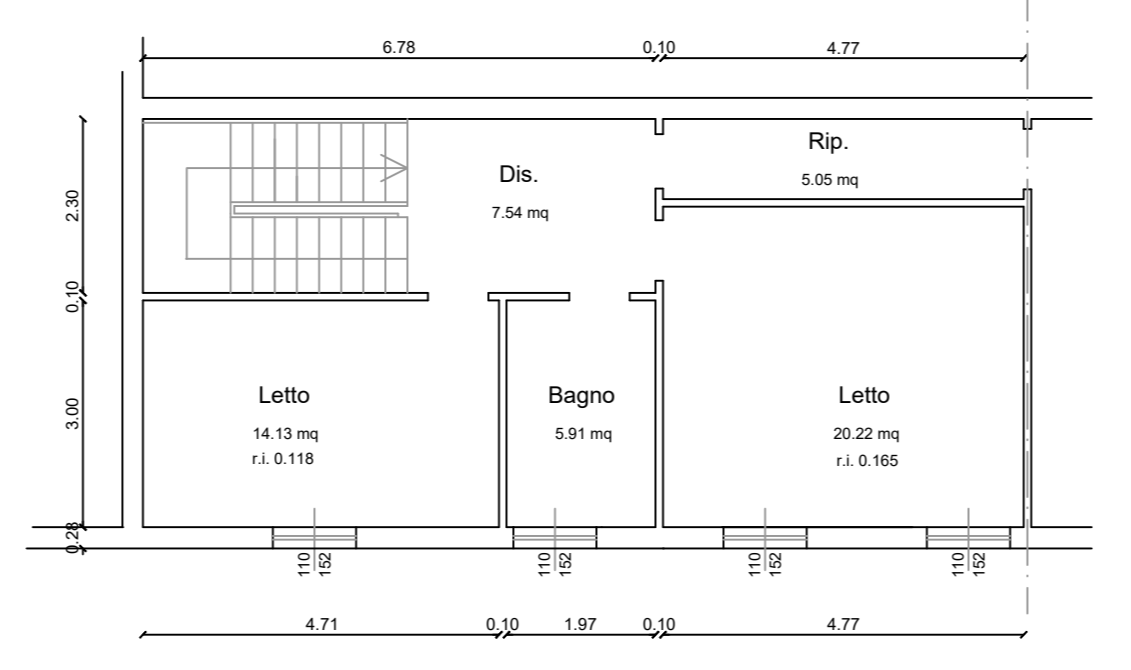

Piano Primo
h = 2.75 m

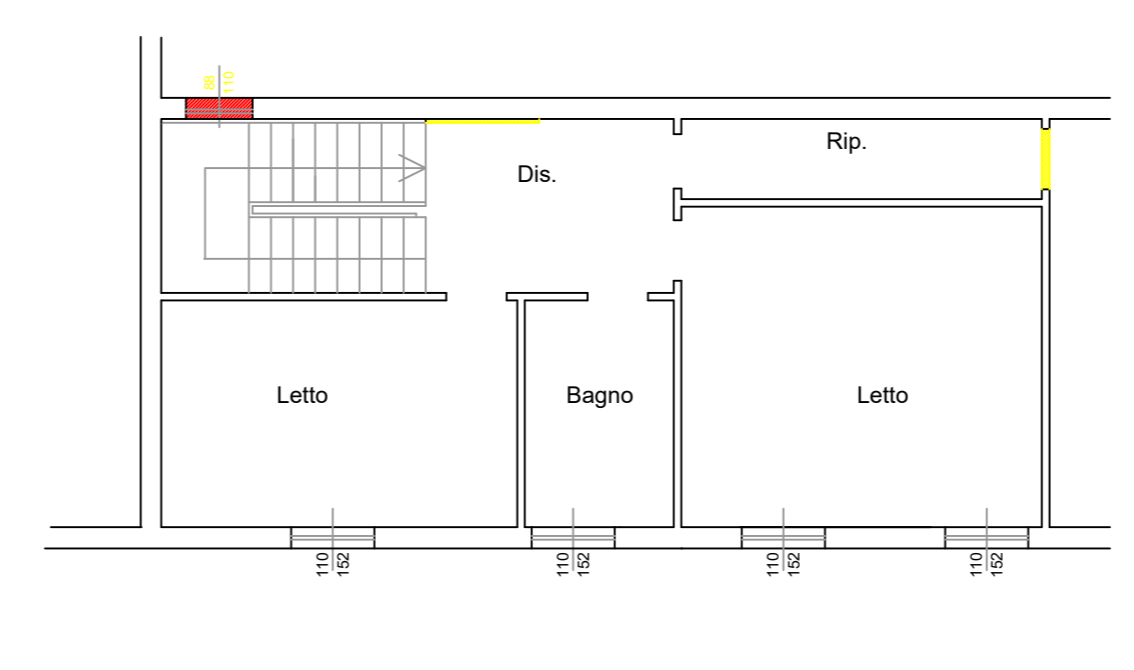

Piano Primo
h = 2.75 m

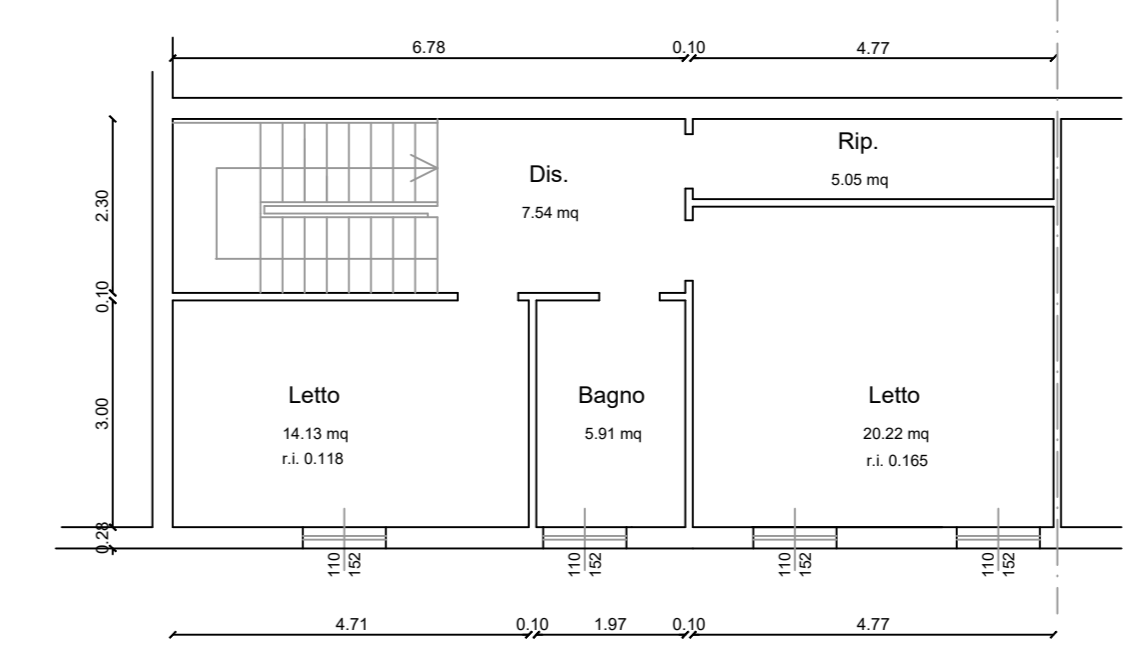

Piano Primo
h = 2.75 m

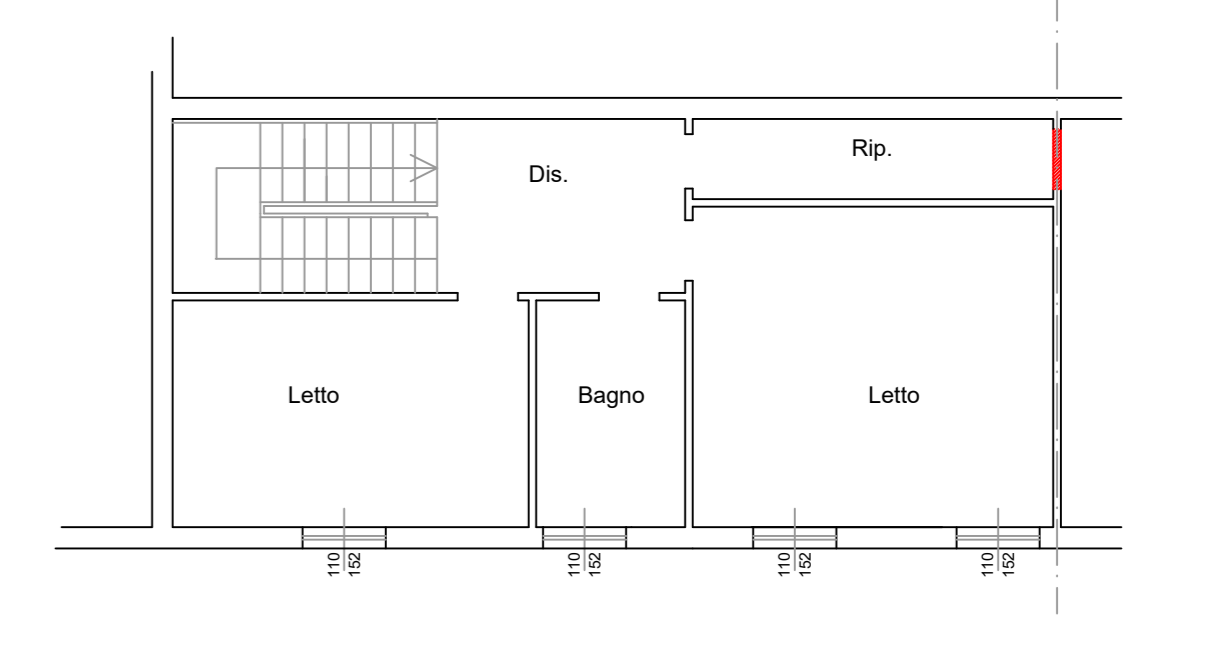

Piano Primo
h = 2.75 m

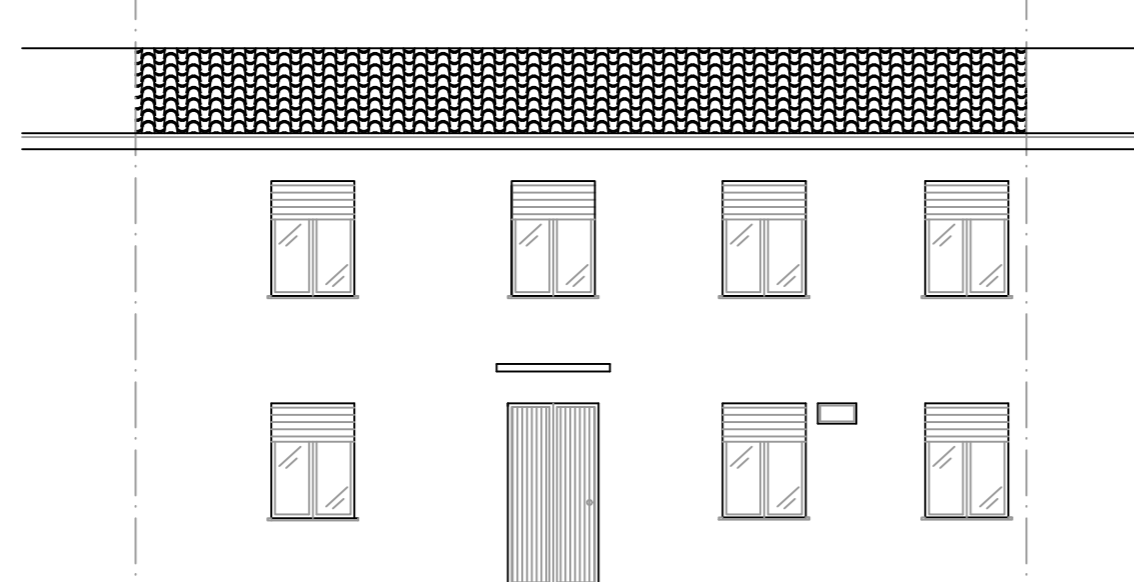

Prospetto Est

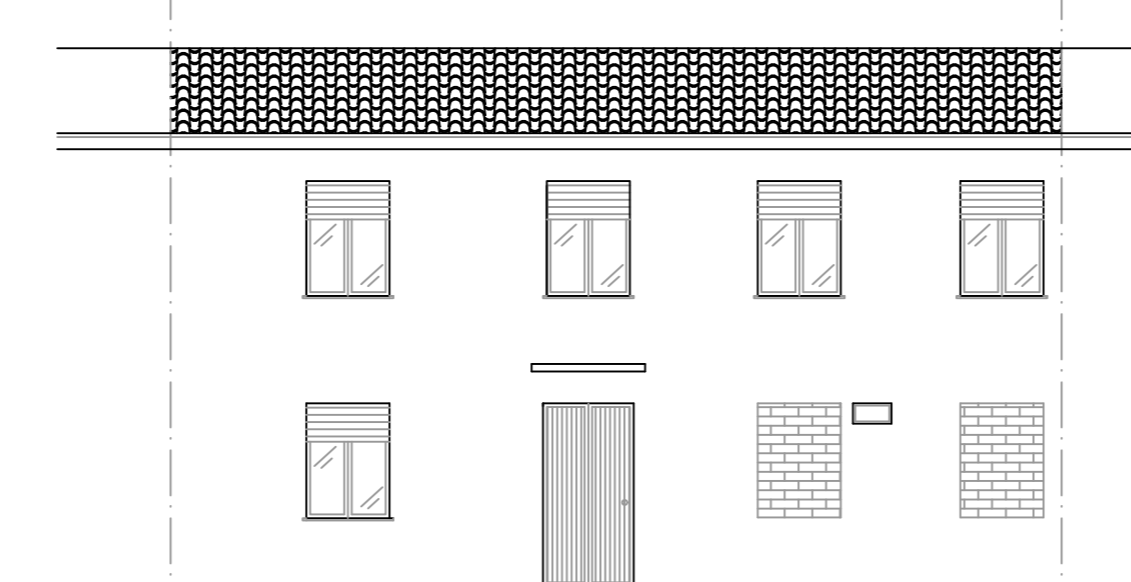

Prospetto Est

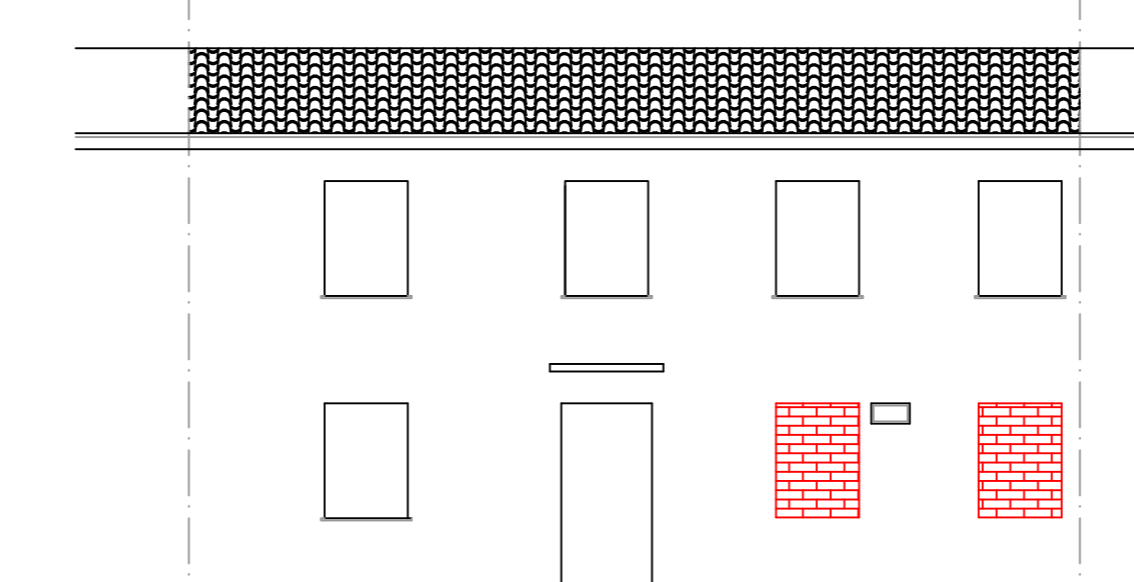

Prospetto Est

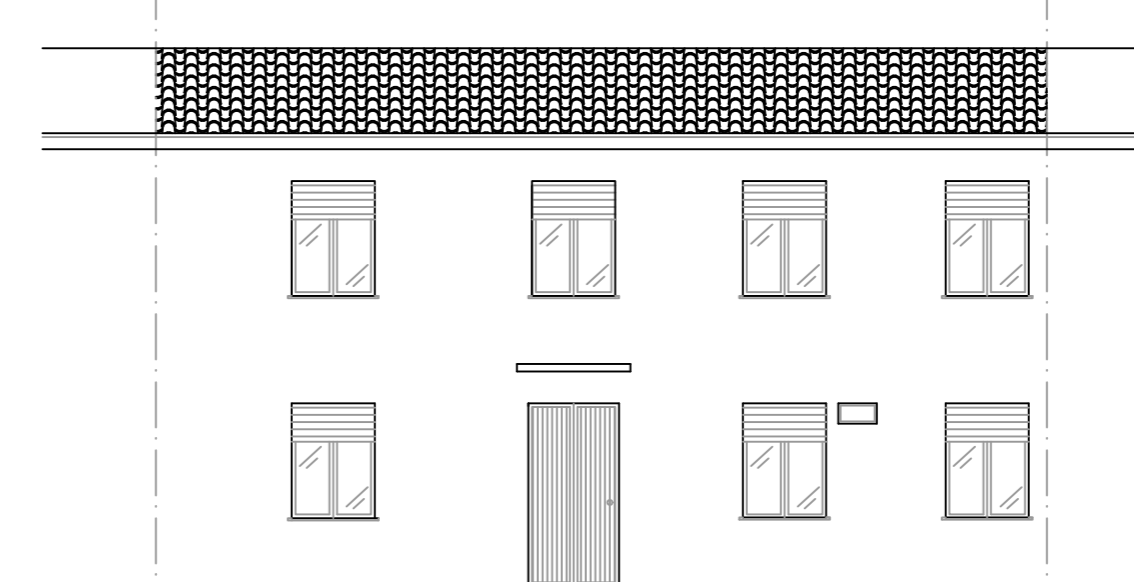

Prospetto Est

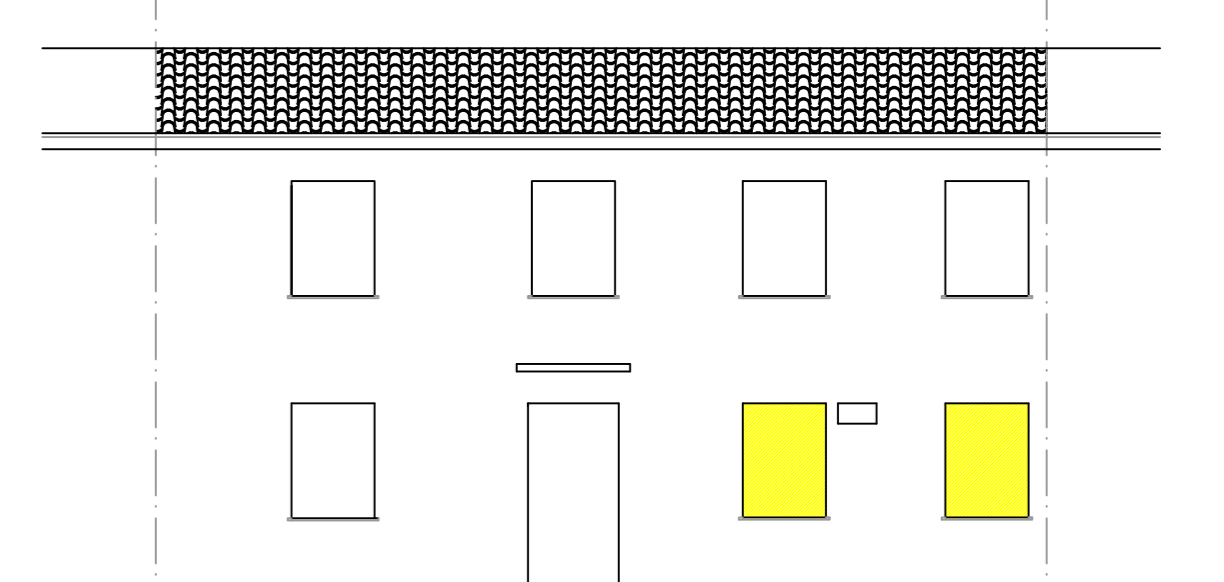

Prospetto Est