

Superficie lorda commerciale mq 49,22  
 Superficie utile mq 38,40  
 Superficie lorda balconi mq 18,57  
 Superficie utile balconi mq 16,70

<b>Tribunale di Velletri</b>	
Es.Imm. 256/2023	G.E. Dott.E. Colognesi
[Redacted]	
Abitazione 1°PIANO	
<b>TAV. 1</b>	<b>RILIEVO</b>
scala 1.100	
Via Vittoria Colonna 22 - Lariano fg. 9 part.IIa 3080 sub 504	

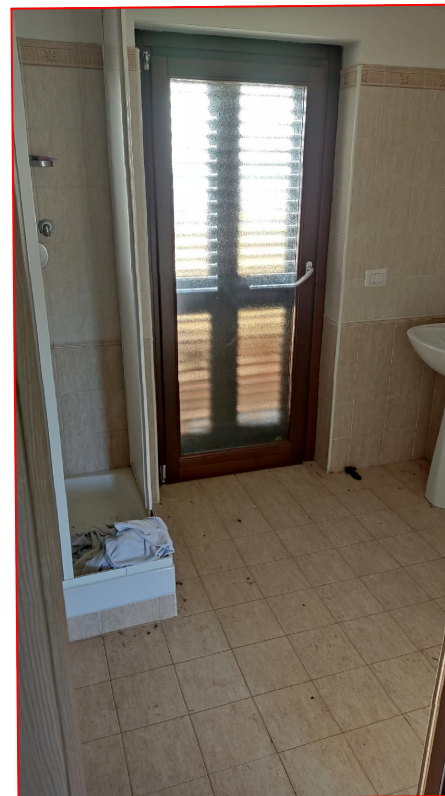
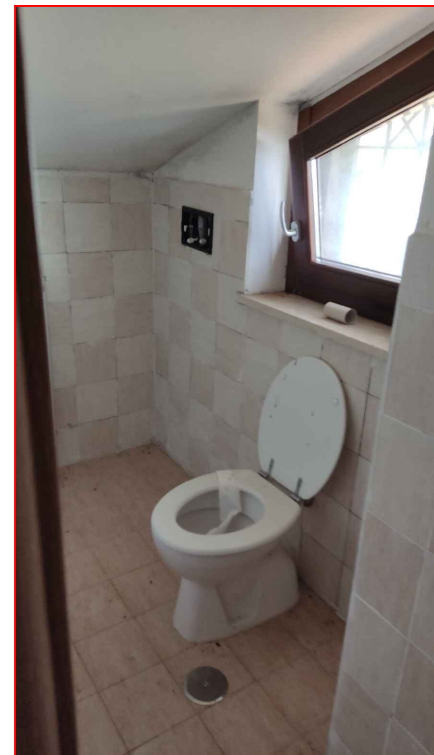
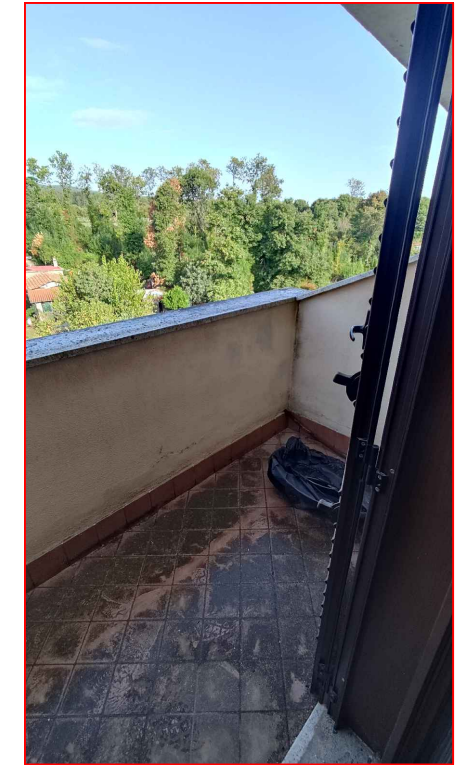
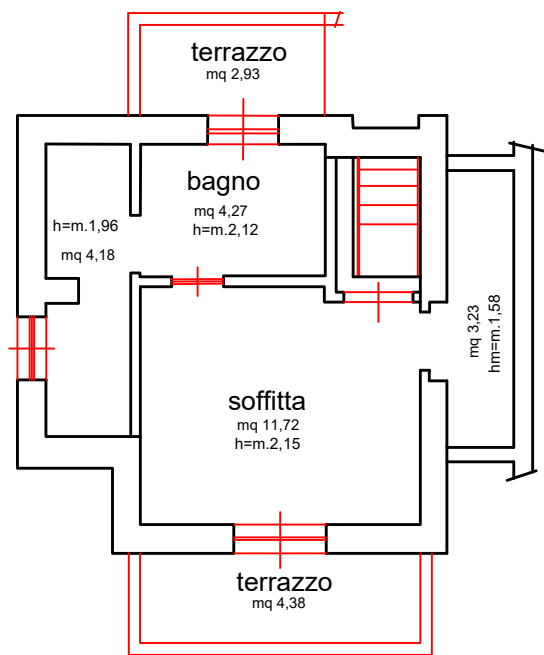

Superficie lorda commerciale    mq 35,95  
 Superficie utile                    mq 23,40  
 Superficie lorda balconi        mq 8,89  
 Superficie utile balconi        mq 7,31

<b>Tribunale di Velletri</b>	
Es.Imm. 256/2023	G.E. Dott.E. Colognesi
SOFFITTA sottotetto	
<b>TAV. 2</b>	<b>RILIEVO</b>
scala 1.100	
Via Vittoria Colonna 22 - Lariano      fg. 9 part.IIa 3080 sub 504	

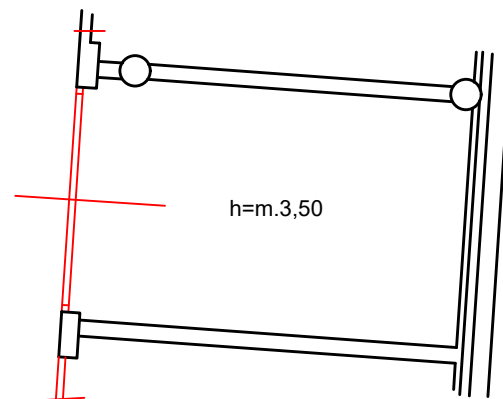
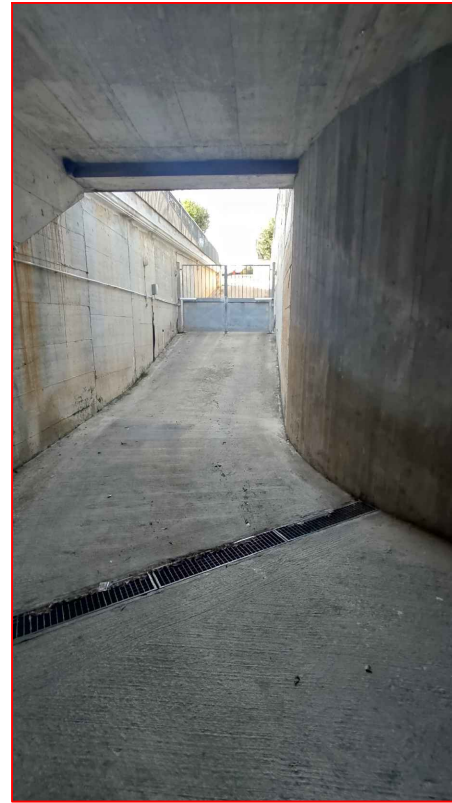

Superficie lorda commerciale mq 19,38  
Superficie utile mq 16,61

<b>Tribunale di Velletri</b>	
Es.Imm. 256/2023	G.E. Dott.E. Colognesi
[REDACTED]	
BOX-AUTO-piano S1	
<b>TAV. 3</b>	<b>RILIEVO</b>
scala 1.100	
Via Vittoria Colonna 22 - Lariano	
fg. 9 part.IIa 3080 sub 26	