

ALLEGATO H 2 -
 APPARTAMENTO PIANO TERRA E SEMINTERRATO -
 SUBALTERO 5 - INTERNO 1

SCALA 1:100

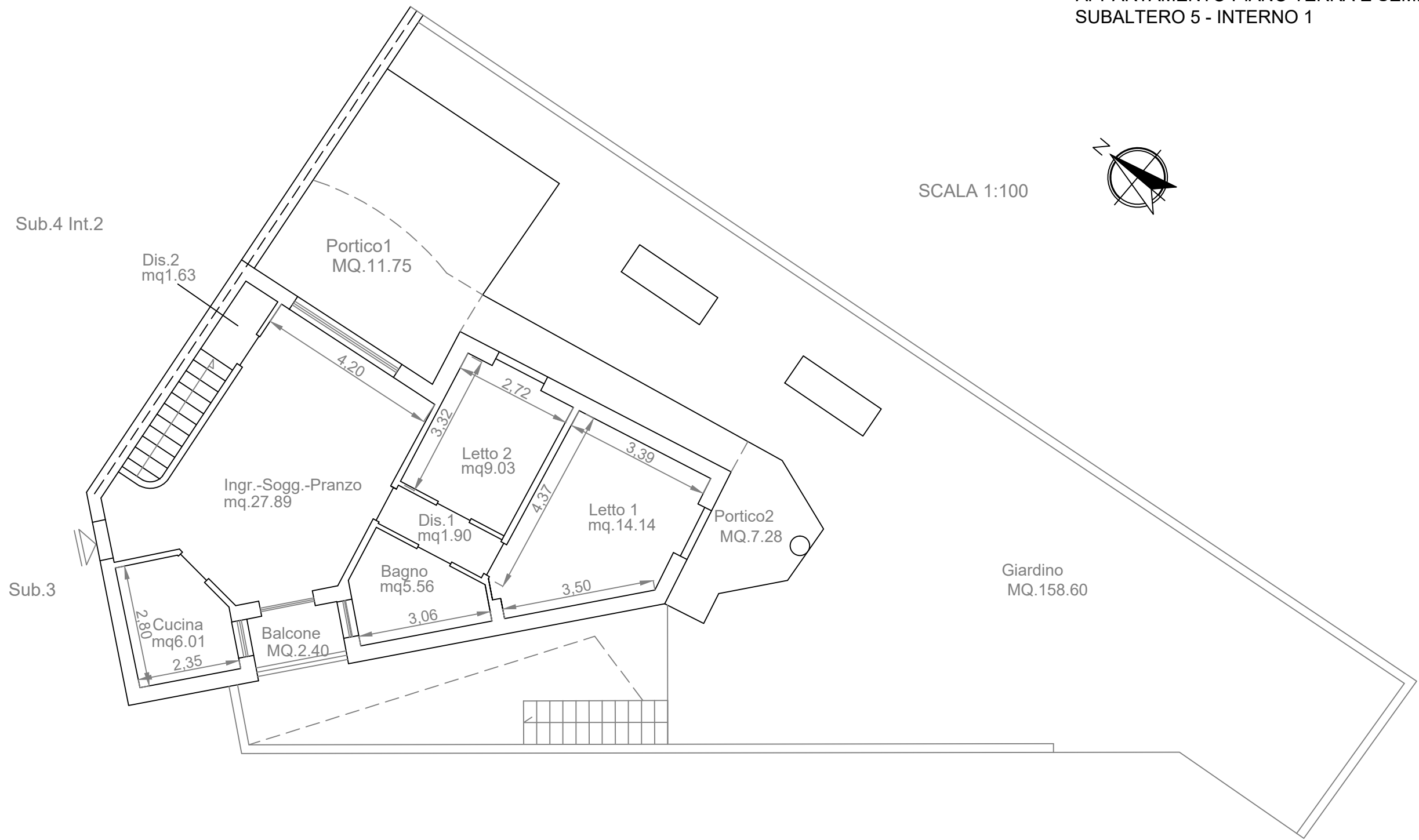
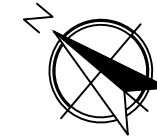

Piano Terra		
Sup.Ut. Res.		mq. 66.16
S.N.R..		mq. 21.42
Sup.Lorda		mq. 86.96
Giardino		mq.158.60
H media m.		2.71

ALLEGATO H 2 -
 LOCALI ACCESSORI AL SEMINTERRATO -
 SUBALTERO 5 - INTERNO 1

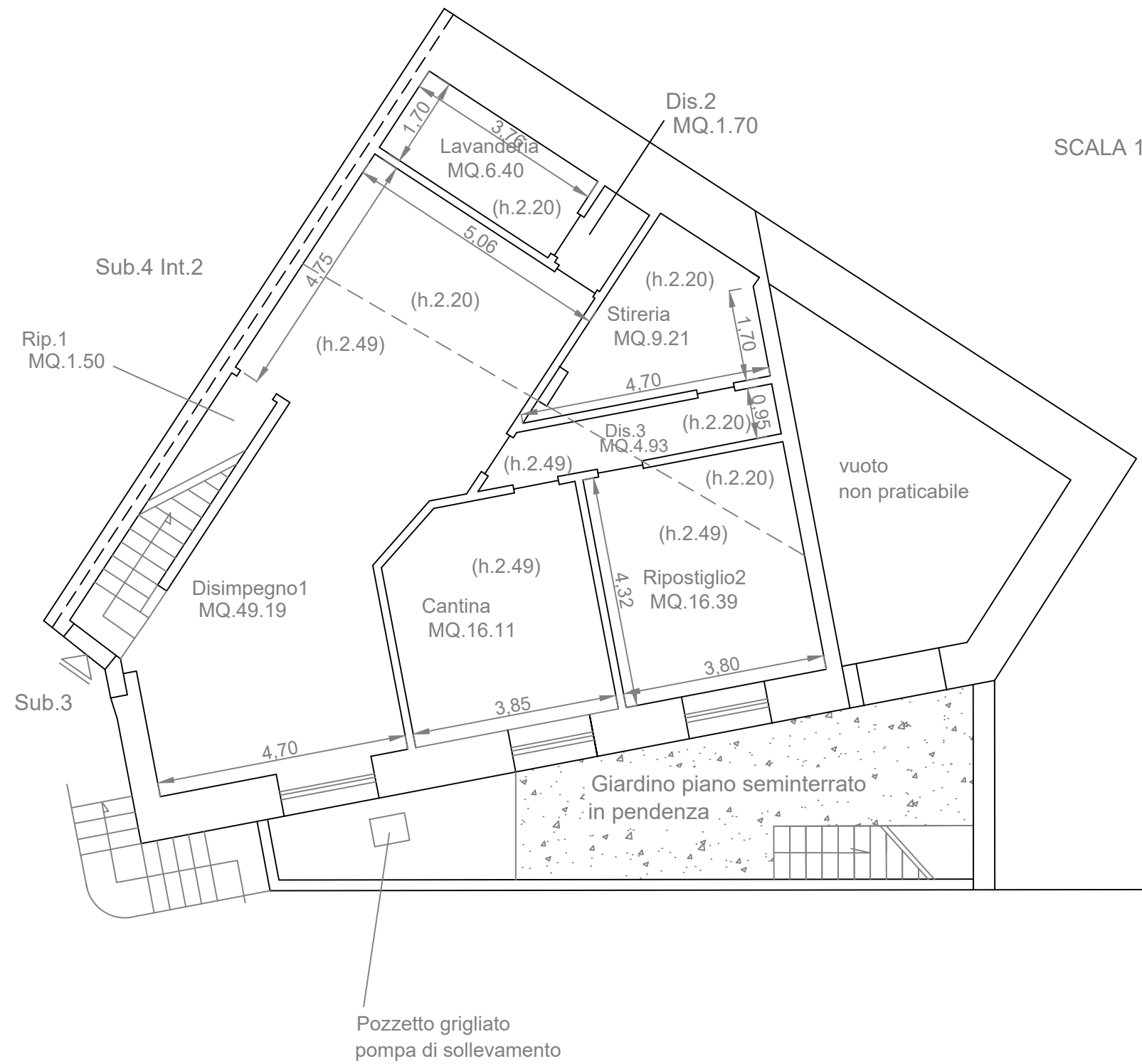

SCALA 1:100

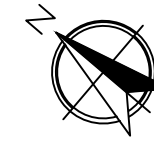

Piano Seminterrato	
Locali Accessori Sup.	mq.105.43
Sup.Lorda	mq.142.55
H media m. 2.34	

ALLEGATO H 2 -
GARAGE PIANO SEMINTERRATO- SUBALTERNO 12

(TERRAPIENO)

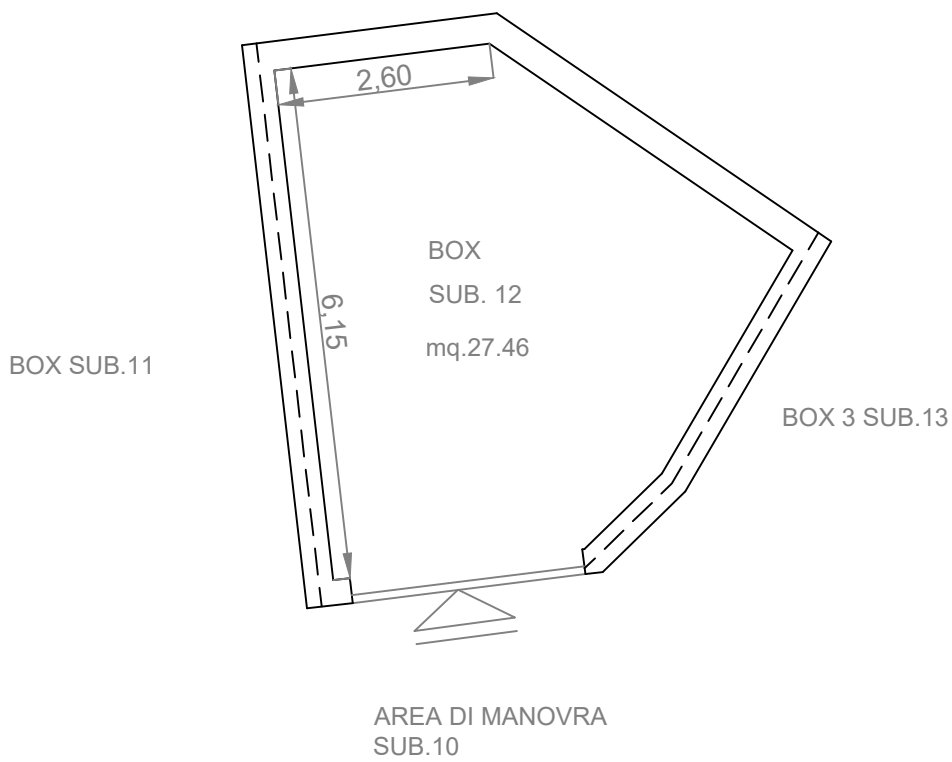

SCALA 1:100

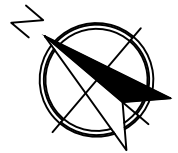

S.N.R.	mq. 27.46
Sup. Lorda	mq. 32.83
H m.	2.51